

**READ AND SAVE
THESE INSTRUCTIONS**



No.:
Date:

II-112
October, 2007

INDUSTRIAL MODELS: AFA, AFB, CFA, CFC, CFX, CFY ECA, ECB, EWD, FSA, FSB



Installation & Maintenance Instructions

WARNING: TO REDUCE THE RISK OF FIRE, ELECTRIC SHOCK, OR INJURY TO PERSONS, OBSERVE THE FOLLOWING:

- A. Use this unit only in the manner intended by the manufacturer. If you have any questions, contact the manufacturer.
- B. Before servicing or cleaning unit, switch power off at service panel and lock the service disconnecting means to prevent power from being switched on accidentally. When the service disconnecting means cannot be locked, securely fasten a prominent warning device, such as a tag, to the service panel.
- C. Installation work and electrical wiring must be done by qualified person(s) in accordance with all applicable codes and standards, including fire-rated construction.
- D. Sufficient air is needed for proper combustion and exhausting of gases through the flue (chimney) of fuel burning equipment to prevent back drafting. Follow the heating equipment manufacturer's guideline and safety standards such as those published by the National Fire Protection Association (NFPA), and the American Society for Heating, Refrigeration and Air Conditioning Engineers (ASHRAE), and local code authorities.
- E. When cutting or drilling into wall or ceiling, do not damage electrical wiring and other hidden utilities.

UNCRATING

Carefully examine the carton(s) for damage before opening. If the carton is damaged, immediately notify the shipping company. Remove the banding straps. Open the carton(s) and remove all protective packaging. If the unit(s) were shipped on wooden skids, remove all protective wood and all bolts securing the unit to the bottom of the skid. Retain the shipping carton(s) until the unit(s) are installed and properly operating.

ACCESSORIES: If the unit(s) were ordered with optional electrical accessories (door switch, control panel, etc.), the accessories may be found in the carton containing the unit or in a separate carton(s) accompanying the unit(s). **Check all of the cartons/skids for accessories before discarding.**

IMPORTANT: A minimum of 6" is required above the top of the unit to allow for wiring to motor junction box(es). This space is NOT required if the unit is supplied with a unit mounted control panel.

BERNER INTERNATIONAL CORPORATION

New Castle, Pennsylvania

724-658-3551 • 1-800-245-4455 • www.berner.com • airdoors@berner.com

Berner air curtains are designed to create an effective barrier against exterior elements: cold drafts in the winter, hot air in the summer, dust, dirt, debris and flying insects. For year-around protection, units should be mounted on the inside of the building and as close to the top of the door opening as possible or vertically mounted as close to the side of the opening as possible (vertical mount not suitable for gas heated units). Units installed on the outside of the building are to be used exclusively for protection against insects.

I. MOUNTING

- A. Berner models are designed to be mounted by their end flanges, without the need for intermediate support. The unit may be attached to the wall, suspended from overhead or supported by brackets. The style of door will determine the best mounting method. See Figures 1-6. All hangers and supports are to be supplied by others. Air curtain(s) must be installed so that nothing will interfere with the air stream when it is deflected $\pm 20^\circ$ to either side of the opening. If the air stream does strike an obstruction, its efficiency will be greatly reduced. Floor brackets are available for vertical mounting.
- B. **IMPORTANT** See Figures 1-6. The unit should be mounted level with the top of the door opening or level with the side of the opening (for vertical mount). The outlet nozzle shall be located no more than 1" above the top/side of the opening. If the air curtain must be mounted higher, then it must be spaced out from the wall $\frac{3}{8}$ " for every inch the unit is above the opening (4.5" per foot). If the unit is mounted 6" or more away from the opening, side shields are recommended See Figure 1.

II. STEAM/HOT WATER HEATED MODELS

Piping should be done in accordance with local codes and regulations and standard practice. Condensate traps should be sized for three times the amount of condensate expected. All piping, traps and temperature controls are provided by others.

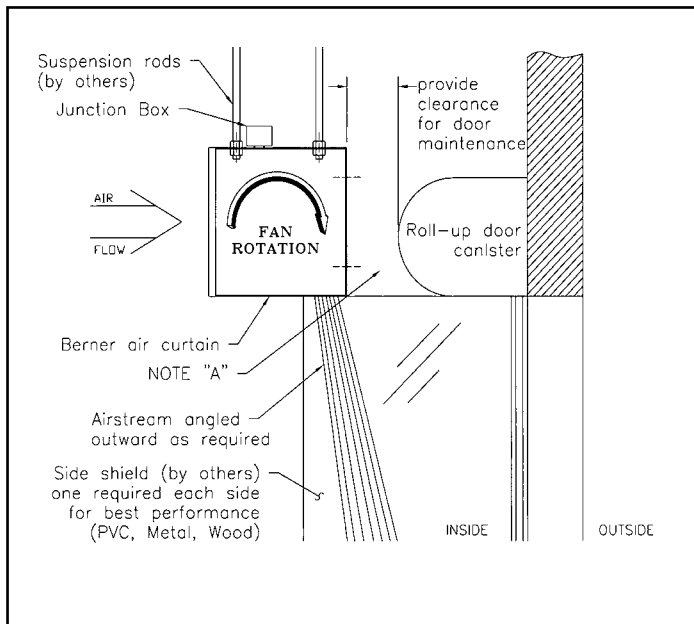

FIGURE 1 - Roll-Up Door

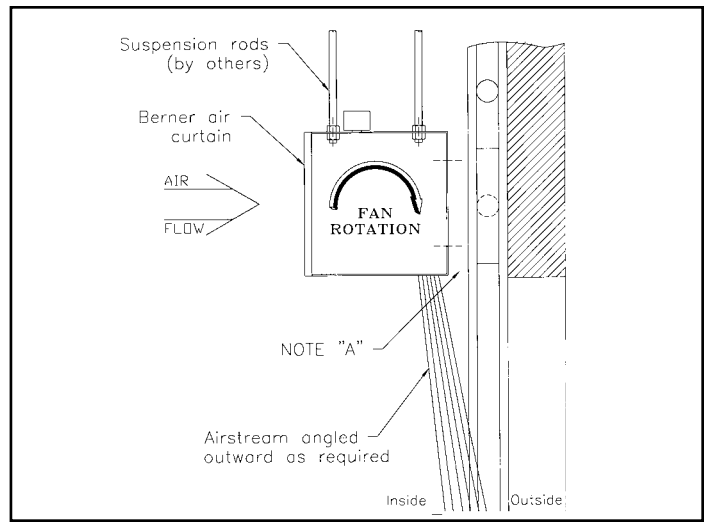

FIGURE 2 - High Rise Track Door

III. ELECTRIC WIRING

All electrical wiring should be done in accordance with: N.E.C., C.E.C., local codes and regulations. Each motor is internally wired to a junction box located on the outside of the unit (one for each motor), or to an optional motor control panel. Control panel wiring diagrams are located on the inside cover of the enclosure.

Make sure the correct voltage as marked on the unit is used. For amp rating, see the name plate located on each junction box or on the control panel.

IV. METHODS OF CONTROL

For convenience of operation, single phase air doors may be operated manually through an On/Off Switch or automatically through a door switch (activates the unit each time the door opens). Three phase units require a motor starter control panel which may also include an On/Off Switch, an Hand/Off/Automatic Switch, or an Automatic Door Switch (activates the unit each time the door opens, and deactivates the unit each time the door closes). The control panel may be unit mounted or remote mounted.

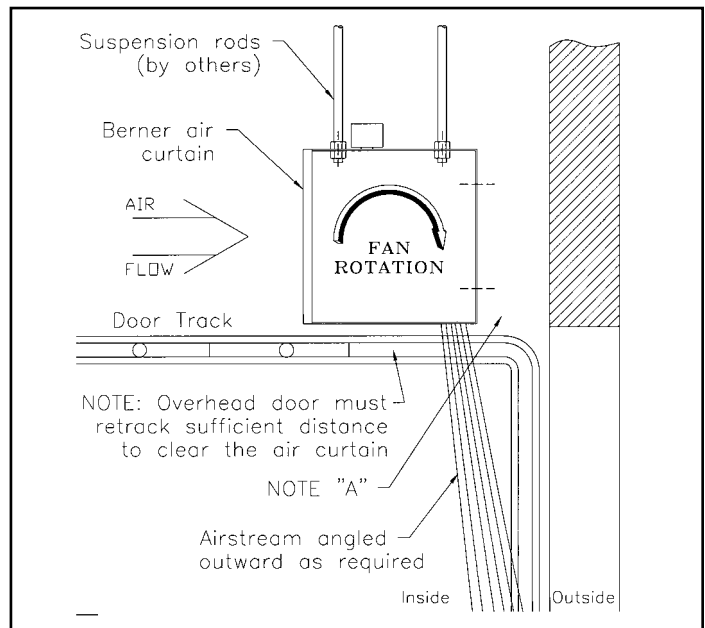

FIGURE 3 - Low "Turn-Back" Track Door

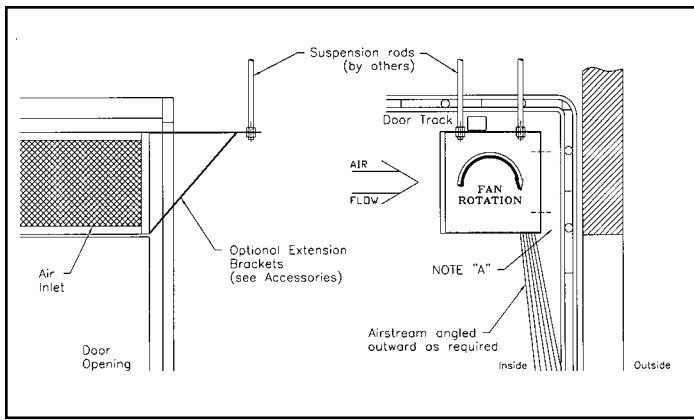

FIGURE 4 - High "Turn-Back" Track Door

V. INTERIOR MOUNTING

(Adjustment For Protecting Against The Weather)
(See Figure 7)

- A. With the air curtain operating, and the door in its full open position, check to see that nothing is obstructing the air flow at the discharge nozzle.
- B. Find the air stream "split" location. Hold a handkerchief, by its top corners, approximately 12" above the floor. Gently move the handkerchief back and forth in the doorway. Make sure the air is being directed to both the inside and the outside. The split location is indicated when the handkerchief is vertical with minimal flutter.
- C. The split location should be approximately 3" outside the doorway. If the split location does not conform to the above specifications, the air directional vanes in the outlet nozzle should be adjusted.

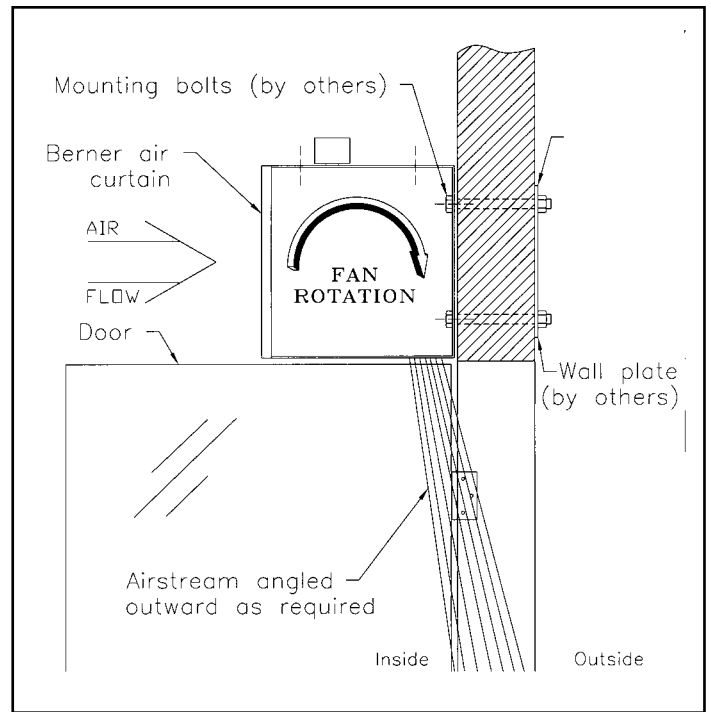

FIGURE 6 - Standard Hinged Door

VI. AIR DIRECTIONAL VANES

- A. Loosen the two nuts on each end of the outlet nozzle(s).
- B. Adjust the angle of the air stream by turning the vanes in the outlet nozzle until the split lies just outside the door threshold. See Figure 7.
- C. After adjustment is complete, tighten the two nuts on each end of the outlet nozzle. Repeat as needed for units with more than one nozzle.

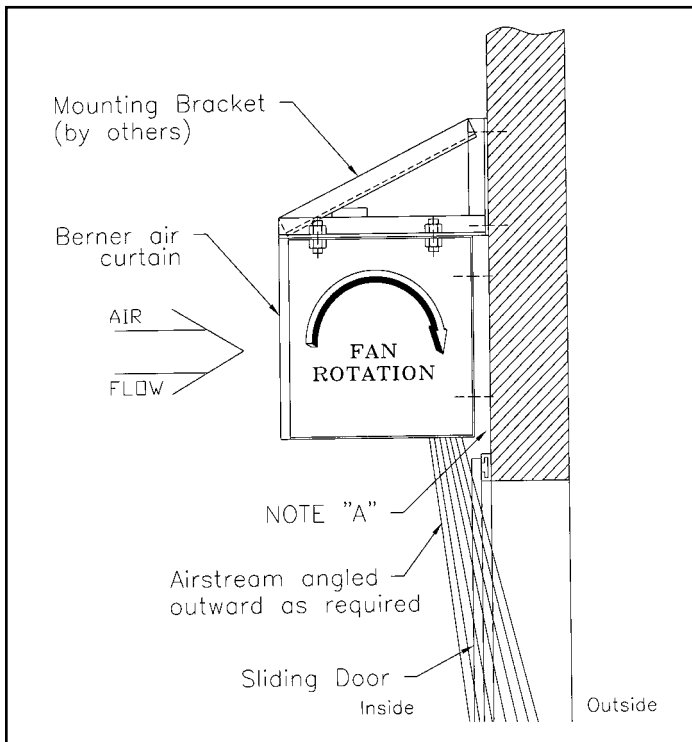

FIGURE 5 - Sliding Doors

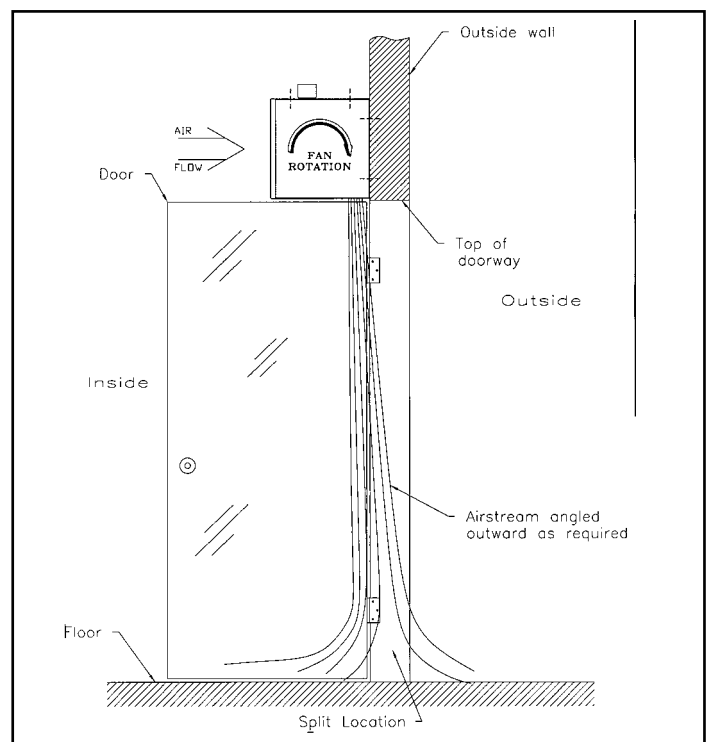

FIGURE 7 - Airstream Flow Pattern

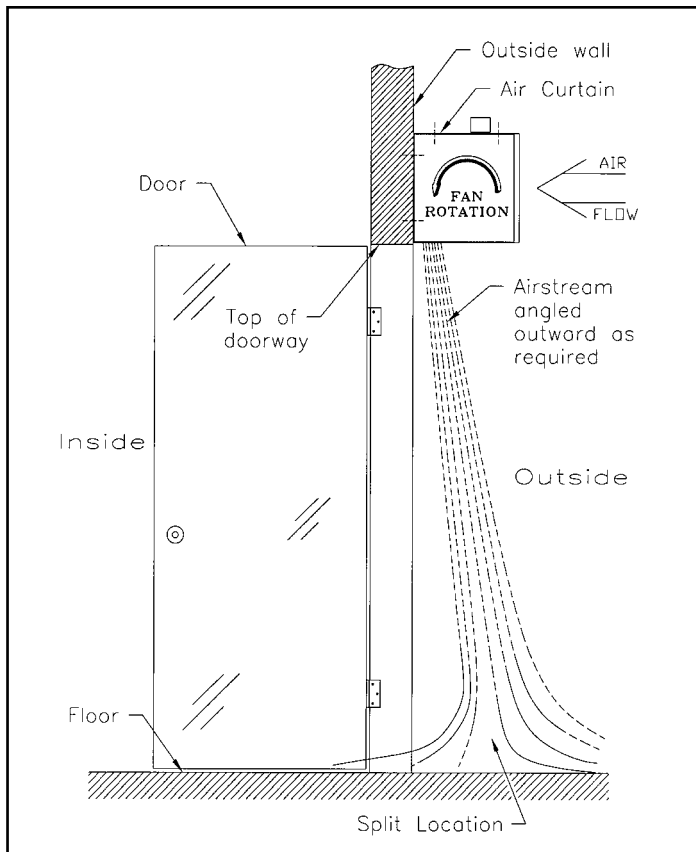

FIGURE 8 - Airstream Location (Exterior)

VII. EXTERIOR MOUNTING

(Adjustments For Protection Against Insects)

(See Figure 8)

Mount the air curtain following the INTERIOR MOUNTING Installation Instructions EXCEPT for air flow adjustment

VIII. AIR FLOW ADJUSTMENT

(For Exterior Insect Control)

Follow the AIR DIRECTIONAL VANES instructions. The split location should be located approximately 6" outside the doorway and approximately 12" above the floor.

NOTE: The in flowing airstream may feel cold, due to the "wind chill factor." The temperature of the moving air can be determined with a thermometer. If this apparent coolness is objectionable to personnel, a heater may be added to your unit.

IX. AIR CONTROL DAMPER

Industrial models are supplied with an air control damper. The air control damper will reduce the air volume supplied by the unit. The air flow may be reduced, if necessary, for light wind conditions. Do not damper the unit unnecessarily, since outside gusts of wind could break through the reduced curtain of air.

X. PREVENTIVE MAINTENANCE & SERVICE

CAUTION: ELECTRIC SHOCK HAZARD

Disconnect power line whenever working on unit. More than one disconnect switch may be required to de-energize the unit for servicing.

Berner air curtains require very little servicing. All parts are easily accessible for periodic inspection and maintenance.

- A. FRONT ACCESS - Maintenance may be performed on ambient (unheated) models by removing the protective inlet screen.
- B. BOTTOM ACCESS - Preventive maintenance may be performed on all models (heated and ambient) by removing the bottom access cover.
- C. ACCESS PANELS: **INDIRECT GAS HEATED MODELS**
Access may be accomplished through the access panels located in the transition duct, or through the bottom access cover of the air curtain.

XI. PREVENTIVE MAINTENANCE & CLEANING

Units should be cleaned and serviced at least twice a year. Your particular application and location (the amount of dirt and dust in the air) of the unit(s) will determine how often your unit(s) will need to be cleaned and serviced. Use an industrial vacuum or compressed air to remove dirt buildup from the inside of the cover housing, air inlet screen, blow wheels/housings, interior of the unit, and heating coils (if applicable).

All motors have permanently lubricated, sealed ball bearings.

TROUBLESHOOTING

SYMPTOMS	CAUSE	REMEDY
NO AIR	<ul style="list-style-type: none"> Power supply line open (no power) Fuse blown/circuit breaker tripped Motor overload tripped 	<ul style="list-style-type: none"> Check power source, check method of control in ON position Replace fuse(s)/reset breaker Internally protected motor - should reset automatically after cool-down, if not, replace motor. Replace switch
	MOTOR RUNNING/FANS ARE NOT ROTATING	
	<ul style="list-style-type: none"> Broken or damaged flexible hub Shaft rotating inside fan 	<ul style="list-style-type: none"> Replace fan sleeve/re-engage coupling Tighten set screws/tighten fan on shaft
MINIMUM AIR	ELECTRICAL CONTROLS NOT FUNCTIONING WHEN DOOR IS OPEN	
	<ul style="list-style-type: none"> Selector switch is in off position Door limit switch not operating 	<ul style="list-style-type: none"> Turn switch to "ON" position Repair or replace limit switch
	<ul style="list-style-type: none"> Air directional discharge vanes mis-adjusted Inadequate intake clearance 	<ul style="list-style-type: none"> Adjust vanes to proper position, see instructions Move air curtain or remove obstruction Provide adequate space for air curtain Improper voltage Free fan from housing Clean and vacuum fan wheels Check fans for blade curve toward discharge
AIR IS NOT HITTING FLOOR	<ul style="list-style-type: none"> Blower motor operates below speed Fan rubbing against housing Fan wheels clogged with dirt Fan in backwards 	<ul style="list-style-type: none"> Adjust nozzle to proper position, adjust motor speed; see installation instructions Remove obstruction or reposition air curtain (move out 3/8" for every 1" up from the door) Relieve negative pressure by providing makeup air
	<ul style="list-style-type: none"> Air stream too weak Air steam hits obstruction Negative pressure 	
UNEVEN AIR	<ul style="list-style-type: none"> Shaft rotating inside fan 	<ul style="list-style-type: none"> Tighten set screws/Replace fan
EXCESSIVE AIR MOVEMENT AT DOORWAY	<ul style="list-style-type: none"> Nozzle not angled out far enough Air movement too cold Pushing air outside building <p>SEE AIR IS NOT HITTING FLOOR SYMPTOMS</p>	<ul style="list-style-type: none"> Adjust nozzle angle to outside Add auxiliary heat to overcome wind chill Adjust discharge angle back into building
ELECTRICALLY HEATED MODELS		
NO HEAT	<ul style="list-style-type: none"> Switch turned to "ON" position Thermostat not set properly Coils burned out due to lack of air Automatic reset thermal cutout failed in open position Manual reset thermal cutout tripped 	<ul style="list-style-type: none"> Replace switch or check wiring Change thermostat setting Correct airflow problem; replace coils Replace automatic thermal cutout Reset manual thermal cutout
MINIMAL HEAT	<ul style="list-style-type: none"> Thermostat in wrong location - thermostat too close to discharge Improper voltage Thermostat not set properly 	<ul style="list-style-type: none"> Move thermostat away from air stream Supply proper voltage Change temperature setting
EXCESSIVE HEAT	<ul style="list-style-type: none"> Thermostat in wrong location Thermostat not set properly Insufficient air over coil Improper voltage 	<ul style="list-style-type: none"> Move thermostat closer to air stream Change temperature setting Remove restriction on intake Supply proper voltage
STEAM/HOT WATER HEATED MODELS		
EXCESSIVE HEAT	<ul style="list-style-type: none"> Too high stream/hot water pressure Inadequate air flow, fins plugged up, dirty coils 	<ul style="list-style-type: none"> Reduce stream pressure/hot water flow Clean intake and coils
MINIMAL HEAT	<ul style="list-style-type: none"> Insufficient removal of condensation (steam) Not enough steam pressure/water temperature too low Intake air below design temperature 	<ul style="list-style-type: none"> Increase trap size Raise pressure for steam/increase water flow Increase steam pressure/increase water flow

WARRANTY

Berner International warrants all new equipment to be free of defects in workmanship and material for a period of five years (5 years) from the original date of shipment, provided the equipment has been properly cared for, installed and operated in accordance with the limits specified on the nameplate and The Company's instructions.

The Company will correct by repair or replacement, at its option and expense, any proven defects in said apparatus, subject to the above conditions, provided that immediate written notice of such defects is given to the Company. The warranty does not include any labor incurred for the removal or installation of defective part(s). The Company reserves the right to inspect, or have inspected by a qualified representative, any apparatus at the place of installation before authorizing repair or replacement. Repair or replacement will be made F.O.B. factory with any applicable transportation charges to be borne by the customer. Merchandise not of the Company's manufacture supplied in piece, or in component assemblies, is not covered by the above warranty, but the Company will give the customer the benefit of any adjustment as made with the Manufacturer.

This warranty is void if the apparatus has been tampered with in any way or shows evidence of misuse.

The Company will not assume any expense or liability for repairs made outside its factory without proper written consent from its service manager, nor for any transportation charges on apparatus returned to the factory without written authorization by the Company.

Nothing in the above warranty provisions, however, shall impose any liability or obligation of any type, nature or description upon Berner International if Berner has not received payment in full for the apparatus in question.

THERE ARE NO WARRANTIES WHICH EXTEND BEYOND THE DESCRIPTION ON THE FACE HEREOF INCLUDING THE IMPLIED WARRANTY OF MERCHANTABILITY AND FITNESS FOR A PARTICULAR PURPOSE.

LIMITATION OF DAMAGES

Notwithstanding anything to the contrary above, customer's exclusive remedy for any and all losses or damages resulting from the sale of The Company's equipment under this agreement, including but not limited to, any allegations of breach of warranty, breach of contract, negligence or strict liability, shall be limited, at The Company's option, to either the return of the purchase price or the replacement of the particular equipment for which a claim is made and proved. In no event shall The Company be liable for any special, consequential, incidental or indirect losses or damages from the sale of The Company's equipment under this agreement.

Serial Number _____ Model Number _____ Date Purchased _____



Berner International Corporation

111 Progress Avenue

New Castle, PA

724-658-3551

1-800-245-4455

www.berner.com

Berner reserves the right to alter specifications without prior notice.

Berner International Corporation New Castle, PA 16101 / USA / Telephone (724) 658-3551 / FAX (724) 652-0682 / www.berner.com / airdoors@berner.com

 MADE IN U.S.A.

©Copyright, 2007 Berner International Corporation