



**READ AND SAVE  
THESE INSTRUCTIONS**

No.  
Date

II-480  
January, 2011

**E-ZONE**  
AIR DOOR  
Made in the USA



**K-ZONE**  
AIR DOOR  
Made in the USA



ANSI/NSF 37  
Air Curtain Fans for  
Customer Entry  
12CS



For Outdoor Use  
KZN/EZN

**Installation & Maintenance Instructions**

**TABLE OF CONTENTS**

I. UNCRATING..... 2  
 II. MOUNTING INSTRUCTIONS..... 2  
 III. WALL MOUNTING ..... 2  
 IV. SUSPENDED MOUNTING..... 3  
 V. ELECTRICAL CONNECTIONS ..... 3  
 VI. MECHANICAL CONNECTIONS ..... 4  
 VII. AIRFLOW ADJUSTMENTS ..... 4  
 VIII. MAINTENANCE AND CLEANING ..... 4  
 IX. SERVICE ..... 4  
 TROUBLESHOOTING ..... 5

To meet NSF Standard 37 requirements, the air curtain width must be greater than or equal to the opening width with a maximum mounting height of 7 feet for all EZN/KZN models.

**WARNING: TO REDUCE THE RISK OF FIRE, ELECTRIC SHOCK OR INJURY TO PERSONS, OBSERVE THE FOLLOWING:**

- A. Use this unit only in the manner intended by the manufacturer. If you have any questions, contact the manufacturer.
- B. Before servicing or cleaning unit, switch power off at service panel and lock the service disconnecting means to prevent power from being switched on accidentally. When the service disconnecting means cannot be locked, securely fasten a prominent warning device, such as a tag, to the service panel.
- C. Installation work and electrical wiring must be done by qualified person(s) in accordance with all applicable codes and standards, including fire-rated construction.
- D. Sufficient air is needed for proper combustion and exhausting of gases through the flue (chimney) of fuel burning equipment to prevent back drafting. Follow the heating equipment manufacturer's guideline and safety standards such as those published by the National Fire Protection Association (NFPA), and the American Society for Heating, Refrigeration and Air Conditioning Engineers (ASHRAE), and local code authorities.
- E. When cutting or drilling into wall or ceiling, do not damage electrical wiring and other hidden utilities.

## I. UNCRATING

Carefully examine the carton(s) for damage before opening. If the carton is damaged, immediately notify shipping company. If the unit(s) were shipped on wooden skids, remove protective wood and banding straps securing the carton(s) to the skid. Open the carton(s) and remove all protective packaging. Remove the plastic cover housing by lifting vertically. Remove and discard four (4) nuts and washers holding the motor/blower section to the bottom of the carton. Remove motor/blower section from the carton.

**CAUTION: ONLY LIFT THE UNIT BY GRASPING INLET RINGS ON THE BLOWER HOUSING WITHOUT TOUCHING BLOWER WHEELS.**

Immediately verify that the electrical rating nameplate located on the cover matches electrical power supply available. Retain the shipping carton(s) until the unit(s) are installed and properly operating.

**ACCESSORIES:** If the unit(s) were ordered with optional electrical accessories (door switch, control panel, etc.), the accessories may be found in the carton containing the unit or in a separate carton(s) accompanying the unit(s). Check all of the cartons/skids for accessories before discarding.

## II. MOUNTING INSTRUCTIONS (General)

The E-Zone/K-Zone air door is designed to be an effective barrier against cold drafts in the winter and hot air in the summer, flying insects and airborne contaminants. To achieve optimum protection, the unit should be mounted on the inside of the building, flush to the wall and as close to the top of the door opening as possible. To ensure peak performance keep air stream free of obstructions.

**The air door will not perform properly if negative air pressure exists in the building. Under these conditions, a means for makeup air to the building must be provided so that the air pressure on both sides of the opening is in balance.**

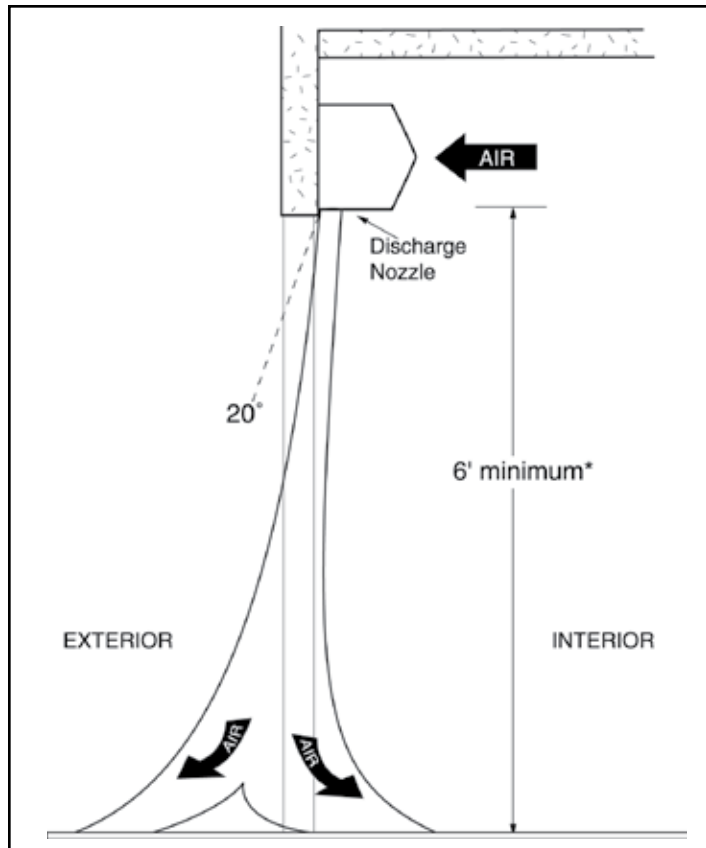

FIGURE 1 - Air Stream

MODEL	Net Weight Ambient (lbs)
EZN/KZN1030A	33
EZN/KZN1036A	38
EZN/KZN1042A	43
EZN/KZN1048A	48
EZN/KZN1060A	57
EZN/KZN1072A	64

TABLE 1 - Weight Chart

Before mounting the unit, check the supporting structure to verify that it has sufficient load-carrying capacity to support the weight of the unit(s). The mounting hardware (supplied by others) should be capable of supporting a minimum of three (3) times the weight of the unit. **See TABLE 1.**

**WARNING: Use caution when mounting the air curtain to ensure adequate clearance is provided for variable speed control knob located on unit bottom. Failure to do so will result in permanent damage to the controller.**

A. When determining the mounting location for the unit(s), make sure that nothing interferes with the curtain of air developed when the discharge vanes are directed from 0° to 20° toward the door opening. If the air stream strikes any obstruction (the top edge of the doorway, a door opening device, etc.), the effectiveness of the unit will be greatly reduced.

**See FIGURE 1**

B. For optimum performance, the bottom of the unit (discharge nozzle) should be no more than 1" above the top of the door opening with the unit mounted flush to the wall. If the unit must be mounted higher, it must be **spaced out** from the wall **3/8" for every inch** the unit is above the door opening. Any void between the air door and the wall should be sealed along the full length of the unit. **See FIGURE 2**

C. Proceed to **Section III-WALL MOUNTING**

## III. WALL MOUNTING

A. Determine the location on the wall above the opening where the air curtain will be mounted. This location should center the unit over the opening and provide suitable mounting support. It is recommended to use at least four locations that correspond to the outer corners of the wall mounting plate.

**See FIGURE 3.**

B. Prepare the wall as necessary for the wall mounting plate anchors (by others).

C. Drill holes in the wall mounting plate to correspond to the locations on the wall.

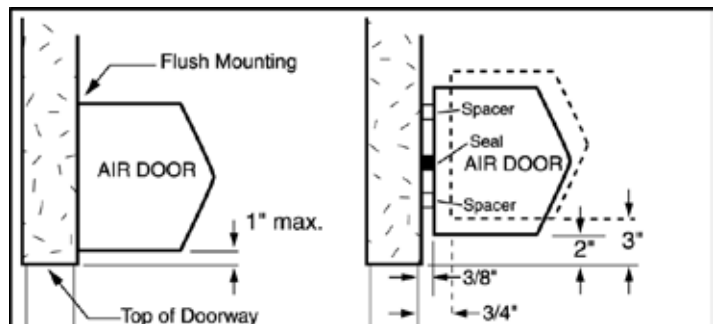
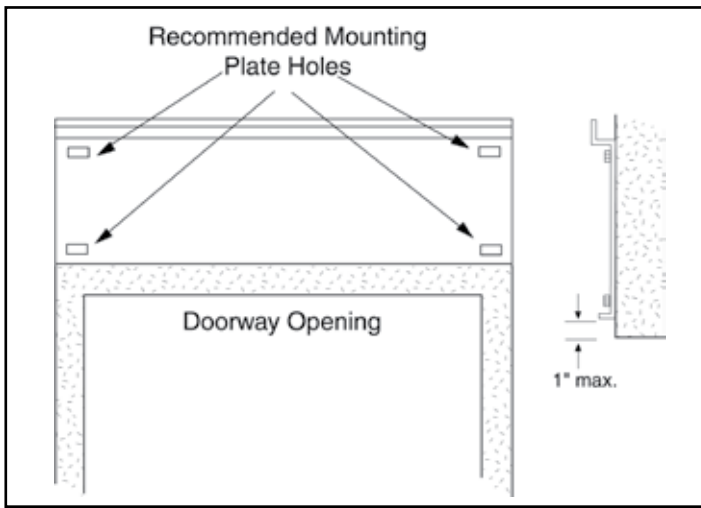

FIGURE 2 - Positioning of Air Door

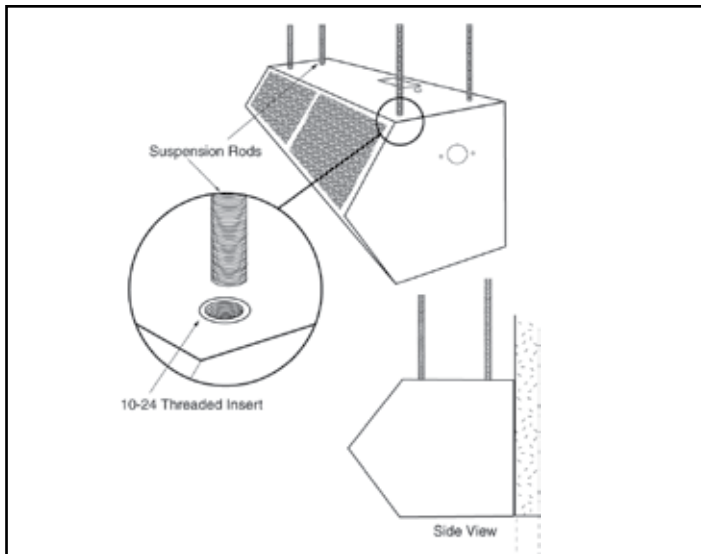

**FIGURE 3 - Positioning of Mounting Plate**

- D. Anchor the wall mounting plate over the door opening with the mounting tabs pointing upwards.
- E. Raise the unit over the door (air discharge nozzle facing down) and on to the mounting plate. First, tilt the unit upward matching the holes in the frame with the tabs on the mounting plate. **See FIGURE 4.**
- F. Lower the unit into place allowing it to rest on the mounting plate. The unit flange should rest above the mounting plate flange.
- G. After the unit is securely seated to the mounting plate, install the locking screws along the bottom flange. **See FIGURE 4.**

#### IV. SUSPENDED MOUNTING (Ceiling Suspension)

- A. When the unit is top mounted, the wall mounting plate is designed to store on the back of unit for future use.
- B. Four (4) factory installed #10-24 threaded inserts are located on the top of the unit for top suspension mounting. **See Figure 5**
- C. Determine the exact mounting location of the air door unit.
- D. The top of the unit is provided with an electrical knockout for power connection. Remove the wiring tray compartment cover. Remove the knockout and attach necessary electrical hardware. Save the wiring diagram found inside of wiring tray.
- E. Attach #10-24 threaded rods, or other suitable hardware to the top mounted threaded inserts.



**FIGURE 5 - Suspended Mounting**

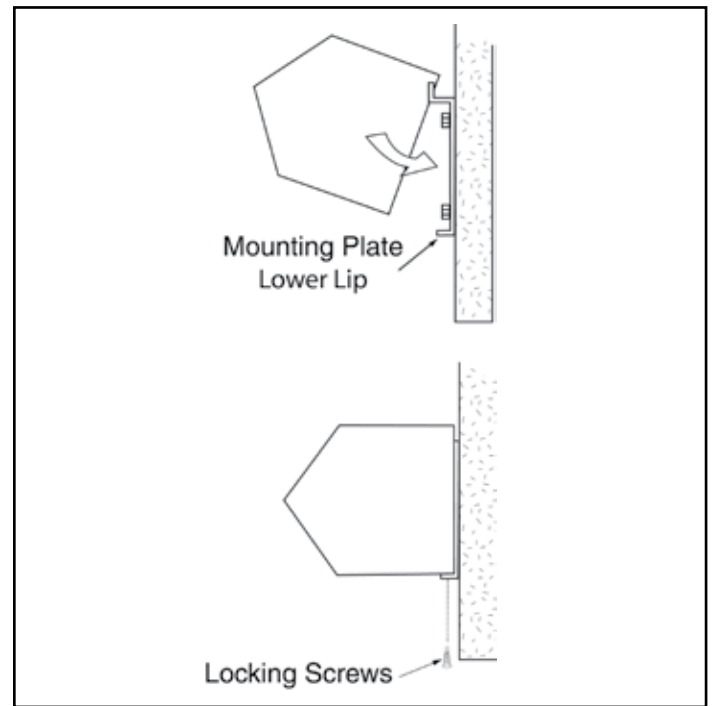

**FIGURE 4 - Attaching Unit to Mounting Plate**

- F. Proceed to **Section V - Electrical Connections**

#### V. ELECTRICAL CONNECTIONS

All electrical wiring and connections **MUST** be performed by qualified personnel in accordance with the latest edition of the National Electrical Code ANSI/NFPA No. 70 or, in Canada, the Canadian Electrical Code, Part 1-C.S.A. Standard C22.1 and local codes and regulations.

- A. Check the rating nameplate on the unit for supply voltage and current requirements. A separate line voltage supply with a suitable branch circuit protection device should be run directly from the main electrical panel to the unit. A disconnect switch for each branch circuit is a required part of this installation. **See TABLE 2**
- B. All field wiring must be copper with a minimum insulation of 60°C within approved conduit. If any of the wire supplied with the unit must be replaced, it must be replaced with copper wiring with a minimum insulation of 90°C.
- C. Remove the wiring compartment cover located on the top of the unit. **See FIGURE 6**
- D. A ½" knockout is provided next to the wiring compartment

MOTOR DATA			
Model	#Motors @HP	120 V 1ø	208/240 V 1ø
		Total Motor Amps	Total Motor Amps
EZN/KZN1030	1 @ 1/5	3.4	1.7
EZN/KZN1036	1 @ 1/5	3.4	1.7
EZN/KZN1042	1 @ 1/5	3.4	1.7
EZN/KZN1048	1 @ 1/5	3.4	1.7
EZN/KZN1060	1 @ 1/5	3.4	1.7
EZN/KZN1072	1 @ 1/5	3.4	1.7

\*\* Operation at 50 HZ will generate approximately a 17% reduction in performance.

**TABLE 2 - Motor Amp Ratings**

to connect electrical conduit. Connect all supply and control circuit wires according to the wiring diagram.

- E. Reinstall the wiring compartment cover.
- F. Switch on the power at the service disconnect. Turn on the unit and check the sequence of operation against the wiring diagram.
- G. Proceed to **Section VI-AIRFLOW ADJUSTMENTS.**

## VI. AIRFLOW ADJUSTMENTS

### A. AIR STREAM SPLIT ADJUSTMENT

1. With the air door operating and the door in its full open position, check to see that nothing is obstructing the air flow at the discharge nozzle vanes.
2. Find the air stream split location. Hold a handkerchief, by its corners, approximately 12" above the floor. Gently move the handkerchief back and forth in the doorway. Make sure the air is being directed to both the inside and the outside. The split location is indicated where the handkerchief is vertical with minimal or no fluttering. **See FIGURE 7.**
3. Adjust the discharge nozzle vanes so the split location is approximately 3" outside the doorway. This is accomplished by first de-energizing the unit. Remove the cover housing, loosen the nozzle vane locking screws and adjusting vanes.

### B. LOW SPEED ADJUSTMENT

**NOTE: This Section is applicable to units with a factory supplied speed controller only. A speed control device shall not be used on units required to comply with EPH or NSF Standard 37.**

**NOTE: Variable speed controller is not factory set for low speed setting. If low speed setting is desired it must be done after installation.**

**WARNING: Changing the low speed setting too much can cause the motor to stall on low speed.**

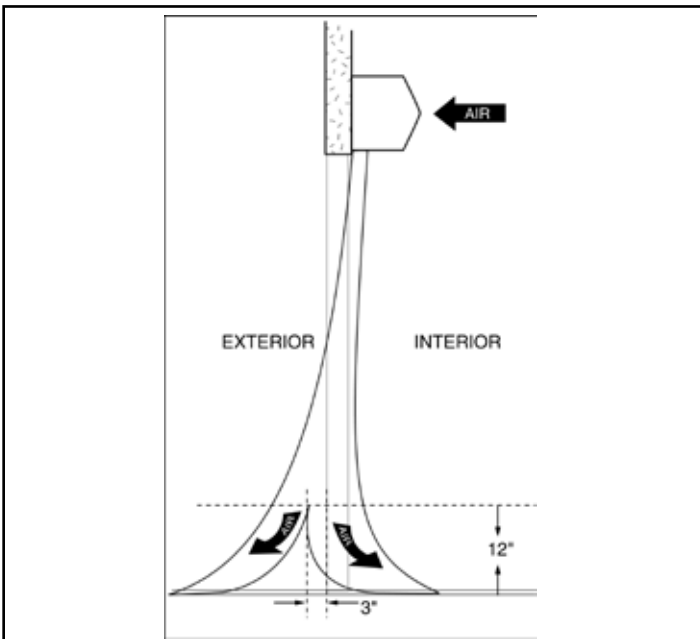

**FIGURE 7 - Air Flow Adjustment**

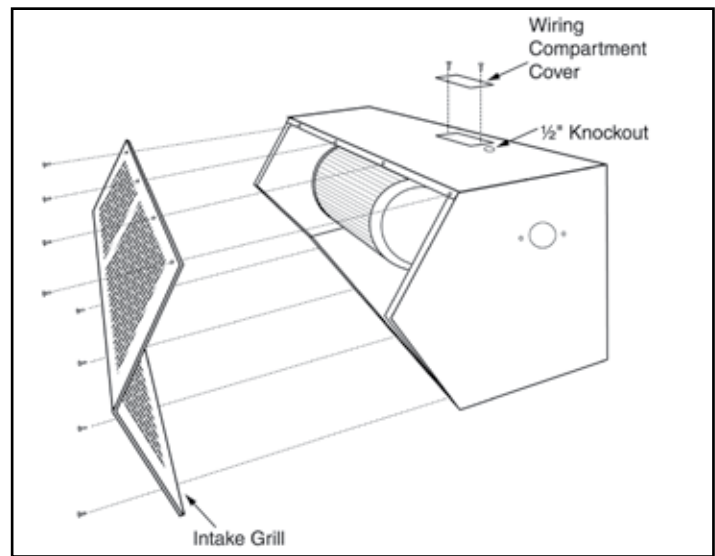

**FIGURE 6 - Junction Box**

1. Turn the speed controller knob clockwise to low speed.
2. Insert a small phillips screwdriver in the hole located next to the speed control knob and slowly turn adjusting screw clockwise to lower the speed. A small degree of rotation is required to change speed. Wait for speed to settle after each turn.

## VII. MAINTENANCE AND CLEANING

**CAUTION: ELECTRIC SHOCK HAZARD Disconnect power whenever servicing unit. More than one disconnect may be required to de-energize unit.**

Keep your air door operating at peak efficiency by cleaning the blower wheels, motor(s) and intake grille. Buildup of dust on the blower wheels can cause vibration, noise and excessive wear on the motor bearings. The frequency of cleaning will depend on the environment where the unit is operating.

Dirty, dusty or greasy environments could require a cleaning schedule of once every two months. If the environment is not that dirty, the unit(s) should be scheduled for cleaning a minimum of once every (6) months. To access the interior of the unit:

- A. Disconnect the power to the unit.
- B. Remove the intake grille by removing all phillips head screws around edge. **See FIGURE 6.**
- C. Vacuum and scrape (if necessary) to remove the buildup of dirt and debris. The motor(s) are permanently lubricated and require no additional lubrication. Reinstall the cover and intake grille.
- D. Switch the power on after cleaning. **CAUTION: STAND CLEAR OF THE UNIT OR WEAR SAFETY GOGGLES AS LOOSE DEBRIS MAY BE PRESENT AND MAY EXIT THE NOZZLE.**

## VIII. SERVICE

**CAUTION: ELECTRIC SHOCK HAZARD Disconnect power whenever servicing unit. More than one disconnect may be required to de-energize unit.**

*Any service performed on the EZN/KZN Series air door **MUST** be done by qualified personnel.*

Berner air doors require very little servicing. All parts are easily accessible for periodic inspection and maintenance. Units should be cleaned at least twice a year. Your particular application (the amount of dirt and dust in the air) and location of the unit(s) will determine how often your unit(s) will need to be cleaned and serviced. All motors have permanently lubricated, sealed, sleeve bearings and require no maintenance.

#### A. UNIT MOUNTED ROTARY SWITCH REMOVAL

The variable speed switch must be removed from the bottom of the unit.

1. Disconnect power to the unit.
2. Remove the intake grille by removing all phillips head screws around edge. **See FIGURE 6.**
3. Disconnect and mark the wires in the unit connected to the switch.
4. Remove the knob from the switch by pulling it straight away from the unit.
5. Remove the two phillips head screws holding the switch and nameplate to the unit.
6. Remove the switch by pushing it into the unit.
7. Reinstall in reverse order of removal.

#### B. FAN AND MOTOR REMOVAL

1. Disconnect power to the unit.
2. Remove the intake grille by removing all phillips head screws around edge. **See FIGURE 6.**
3. Unplug motor harness from motor and remove necessary wiring.
4. Using a 1/8" Allen wrench, loosen each set screw attaching fan(s) to motor.
5. While holding the motor in place, loosen and remove the motor clips.
6. Slide the fans toward the motor so that the ball bearings on the outer fan shaft are exposed.
7. Slowly roll the motor out of the motor mount cradle forward and down. The hubs of the fans are flexible enough to allow the motor to move before the fans' outer ball bearings pull out of the unit.
8. Reinstall in reverse order of removal.

## TROUBLESHOOTING

SYMPTOMS	CAUSE	REMEDY
<b>NO AIR</b>	<ul style="list-style-type: none"> <li>• Electrical Power supply line open (no power)</li> <li>• Fuse blown/circuit breaker tripped</li> <li>• Motor overload tripped</li> <li>• Failed switch</li> </ul>	<ul style="list-style-type: none"> <li>• Check power source, check method of control in ON position</li> <li>• Replace fuse(s)/reset breaker</li> <li>• Internally protected motor - should reset automatically after cool-down, if not, replace motor.</li> <li>• Replace switch</li> </ul>
	<b>MOTOR RUNNING/FANS ARE NOT ROTATING</b>	
	<ul style="list-style-type: none"> <li>• Broken fan hub</li> <li>• Shaft rotating inside fan</li> <li>• Broken / Loose coupling</li> </ul>	<ul style="list-style-type: none"> <li>• Replace fan</li> <li>• Tighten set screws/tighten fan on shaft</li> <li>• Replace / Tighten coupling</li> </ul>
<b>MINIMUM AIR</b>	<b>ELECTRICAL CONTROLS NOT FUNCTIONING WHEN DOOR IS OPEN</b>	
	<ul style="list-style-type: none"> <li>• Selector switch is in off position</li> <li>• Door limit switch not operating</li> </ul>	<ul style="list-style-type: none"> <li>• Turn switch to "ON" position</li> <li>• Repair or replace limit switch</li> </ul>
<b>AIR IS NOT HITTING FLOOR</b>	<ul style="list-style-type: none"> <li>• Air stream too weak</li> <li>• Air stream hits obstruction</li> <li>• Negative pressure</li> </ul>	<ul style="list-style-type: none"> <li>• Adjust vanes to proper position, see instructions</li> <li>• Move air curtain or remove obstruction</li> <li>• Provide adequate space for air curtain</li> <li>• Improper voltage</li> <li>• Free fan from housing</li> <li>• Clean and vacuum fan wheels</li> </ul>
<b>UNEVEN AIR</b>	<ul style="list-style-type: none"> <li>• Shaft rotating inside fan</li> </ul>	<ul style="list-style-type: none"> <li>• Tighten set screws/Replace fan</li> </ul>
<b>EXCESSIVE AIR MOVEMENT AT DOORWAY</b>	<ul style="list-style-type: none"> <li>• Nozzle not angled out far enough</li> <li>• Air movement too cold</li> <li>• Pushing air outside building</li> </ul> <p>SEE AIR IS NOT HITTING FLOOR SYMPTOMS</p>	<ul style="list-style-type: none"> <li>• Adjust nozzle angle to outside</li> <li>• Add auxiliary heat to overcome wind chill</li> <li>• Adjust discharge angle back into building</li> </ul>

# WARRANTY

Berner International warrants all new equipment to be free of defects in workmanship and material for a period of five years (5 years) on unheated models and two years (2 years) on heated models from the original date of shipment, provided the equipment has been properly cared for, installed and operated in accordance with the limits specified on the nameplate and The Company's instructions.

The Company will correct by repair or replacement, at its option and expense, any proven defects in said apparatus, subject to the above conditions, provided that immediate written notice of such defects is given to The Company. The warranty does not include any labor incurred for the removal or installation of defective part(s). The Company reserves the right to inspect, or have inspected by a qualified representative, any apparatus at the place of installation before authorizing repair or replacement. Repair or replacement will be made F.O.B. factory with any applicable transportation charges to be borne by the customer. Merchandise not of The Company's manufacture supplied in piece, or in component assemblies, is not covered by the above warranty, but The Company will give the customer the benefit of any adjustment as made with the Manufacturer.

This warranty is void if the apparatus has been tampered with in any way or shows evidence of misuse.

The Company will not assume any expense or liability for repairs made outside its factory without proper written consent from its service manager, nor for any transportation charges on apparatus returned to the factory without written authorization by The Company.

Nothing in the above warranty provisions, however, shall impose any liability or obligation of any type, nature or description upon Berner International if Berner has not received payment in full for the apparatus in question.

**THERE ARE NO WARRANTIES WHICH EXTEND BEYOND THE DESCRIPTION ON THE FACE HERE OF INCLUDING THE IMPLIED WARRANTY OF MERCHANTABILITY AND FITNESS FOR A PARTICULAR PURPOSE.**

## LIMITATION OF DAMAGES

**Notwithstanding anything to the contrary above, customer's exclusive remedy for any and all losses or damages resulting from the sale of The Company's equipment under this agreement, including but not limited to, any allegations of breach of warranty, breach of contract, negligence or strict liability, shall be limited, at The Company's option, to either the return of the purchase price or the replacement of the particular equipment for which a claim is made and proved. In no event shall The Company be liable for any special, consequential, incidental or indirect losses or damages from the sale of The Company's equipment under this agreement.**

SERIAL NUMBER	MODEL NUMBER	DATE PURCHASED
---------------	--------------	----------------



**BERNER INTERNATIONAL CORPORATION**  
**New Castle, Pennsylvania**

**724-658-3551 • 1-800-245-4455 • [www.berner.com](http://www.berner.com) • [airdoors@berner.com](mailto:airdoors@berner.com)**

*Berner reserves the right to alter specifications without prior notice.*