



**READ AND SAVE
THESE INSTRUCTIONS**

No.
Date

II-123
June, 2010

STAR[®]
AIR DOOR
MADE IN THE USA

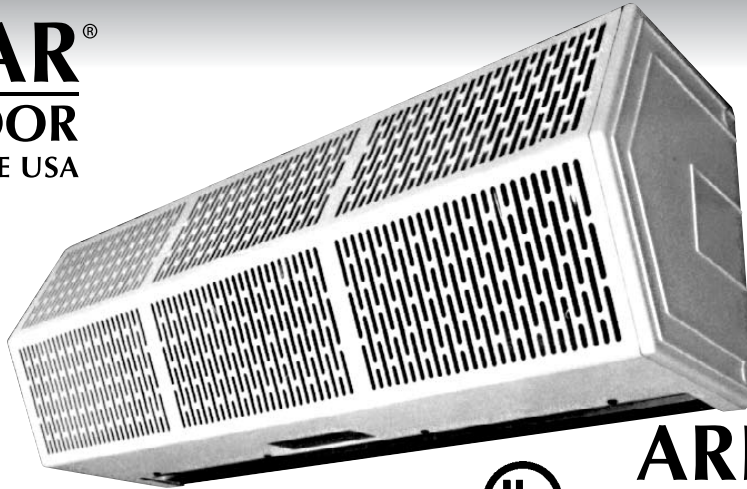

ARISTOCRAT[®]
AIR DOOR
MADE IN THE USA

Installation & Maintenance Instructions

TABLE OF CONTENTS

I. UNCRATING.....	2
II. MOUNTING INSTRUCTIONS.....	2
III. WALL MOUNTING	3
IV. SUSPENDED MOUNTING.....	3
V. ELECTRICAL CONNECTIONS	3
VI. MECHANICAL CONNECTIONS	4
VII. AIRFLOW ADJUSTMENTS	4
VIII. MAINTENANCE AND CLEANING	5
IX. SERVICE	5
TRUBLESHOOTING	7

NSF certification requires maximum mounting height of 7 feet for models ASN/STN 36" & 42"
EPH certification requires maximum mounting height of 7 feet for all ASN/STN models

WARNING: TO REDUCE THE RISK OF FIRE, ELECTRIC SHOCK OR INJURY TO PERSONS, OBSERVE THE FOLLOWING:

- A. Use this unit only in the manner intended by the manufacturer. If you have any questions, contact the manufacturer.
- B. Before servicing or cleaning unit, switch power off at service panel and lock the service disconnecting means to prevent power from being switched on accidentally. When the service disconnecting means cannot be locked, securely fasten a prominent warning device, such as a tag, to the service panel.
- C. Installation work and electrical wiring must be done by qualified person(s) in accordance with all applicable codes and standards, including fire-rated construction.
- D. Sufficient air is needed for proper combustion and exhausting of gases through the flue (chimney) of fuel burning equipment to prevent back drafting. Follow the heating equipment manufacturer's guideline and safety standards such as those published by the National Fire Protection Association (NFPA), and the American Society for Heating, Refrigeration and Air Conditioning Engineers (ASHRAE), and local code authorities.
- E. When cutting or drilling into wall or ceiling, do not damage electrical wiring and other hidden utilities.

I. UNCRATING

Carefully examine the carton(s) for damage before opening. If the carton is damaged, immediately notify shipping company. If the unit(s) were shipped on wooden skids, remove protective wood and banding straps securing the carton(s) to the skid. Open the carton(s) and remove all protective packaging. Remove the plastic cover housing by lifting vertically. Remove and discard four (4) nuts and washers holding the motor/blower section to the bottom of the carton. Remove motor/blower section from the carton.

CAUTION: ONLY LIFT THE UNIT BY GRASPING INLET RINGS ON THE BLOWER HOUSING WITHOUT TOUCHING BLOWER WHEELS.

Immediately verify that the electrical rating nameplate located on the cover matches electrical power supply available. Retain the shipping carton(s) until the unit(s) are installed and properly operating.

ACCESSORIES: If the unit(s) were ordered with optional electrical accessories (door switch, control panel, etc.), the accessories may be found in the carton containing the unit or in a separate carton(s) accompanying the unit(s). Check all of the cartons/skids for accessories before discarding.

II. MOUNTING INSTRUCTIONS (General)

INDOOR MOUNTING - Environmental/Insect Dust Control

OUTDOOR MOUNTING (Unheated Only) - Insect/Dust Control

The Aristocrat/Star Air Door is designed to be an effective barrier against cold drafts in the winter and hot air in the summer. To achieve optimum protection, the unit should be mounted on the inside of the building, flush to the wall and as close to the top of the door opening as possible. To ensure peak performance keep air stream free of obstructions.

The Air Door will not perform properly if negative air pressure exists in the building. Under these conditions, a means for makeup air to the building must be provided so that the air pressure on both sides of the opening is in balance.

Before mounting the unit, check the supporting structure to verify that it has sufficient load-carrying capacity to support the weight of the unit(s). The mounting hardware (supplied by others) should be capable of supporting a minimum of three (3) times the weight of the unit. **See Table 1.**

Model	Net Weight Ambient (lbs)	Net Weight Electric (lbs)
ASF/STF 1036	50	55
ASR/STR/ASN/STN 1036	52	57
ASF/STF 1042	52	57
ASR/STR/ASN/STN 1042	54	59
ASF/STF 1048	54	59
ASR/STR/ASN/STN 1048	56	61
ASF/STF 1060-2	56	61
ASF/STF 1060-3	60	65
ASR/STR/ASN/STN2060	70	75
ASR/STR 1060	58	63
ASF/STF 1072	70	75
ASF/STF 2072	80	85
ASR/STR/ASN/STN 2072	84	89

TABLE 1 - Unit Weight

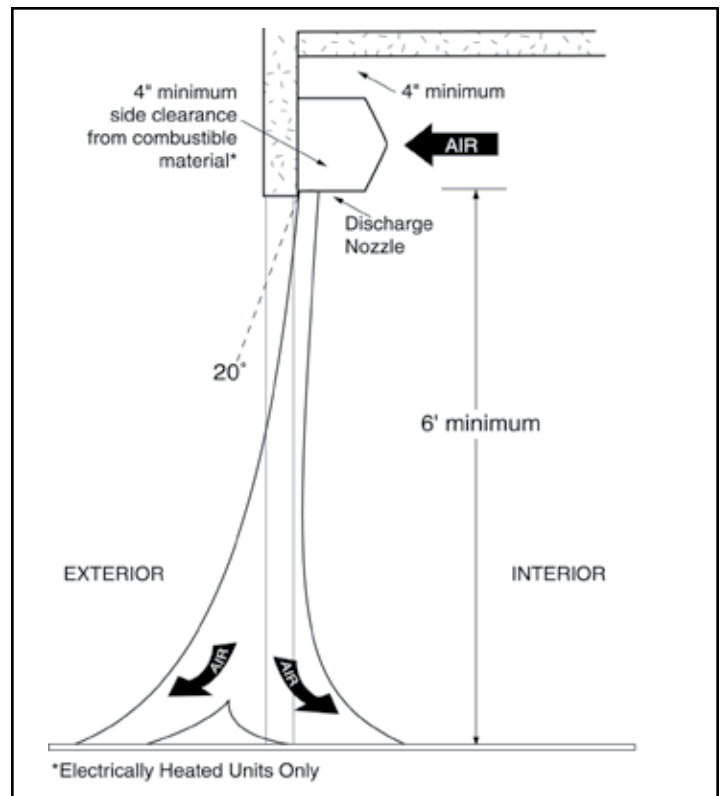

FIGURE 1 - Air Stream

NOTE: The Air Door is weatherproof, therefore no special covering is required for outdoor mounting.

IMPORTANT: A minimum of 4" is recommended above the top of the Air Door for the installation and removal of the cover housing.

- When determining the mounting location for the unit(s), make sure that nothing interferes with the curtain of air developed when the discharge vanes are directed from 0° to 20° toward the door opening. If the air stream strikes any obstruction (the top edge of the doorway, a door opening device, etc.), the effectiveness of the unit will be greatly reduced. **See Figure 1.**
- For optimum performance, the bottom of the unit (discharge nozzle) should be no more than 1" above the top of the door opening with the unit mounted flush to the wall. If the unit must be mounted higher, it must be **spaced out** from the wall $\frac{3}{8}$ " for every inch the unit is above the door opening. For optimum protection, any void between the Air Door and the wall should be sealed along the full length of the unit.

See Figure 2.

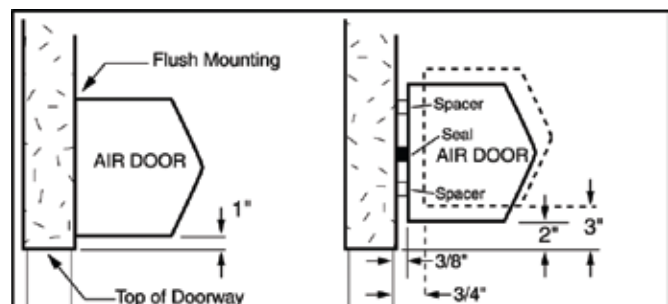

FIGURE 2

C. **Electric heated units shall:**

1. Have a minimum clearance of at least 4" between the sides and top of the unit and any combustible material.
2. Have a minimum clearance of at least 6' between the bottom of the unit and the floor.
3. Be installed indoors only.

D. Proceed to either **Section III - WALL MOUNTING**, or **Section IV SUSPENDED MOUNTING**

III. WALL MOUNTING

To prevent damage to the Air Door during shipping, the unit is shipped with each blower attached to the back plate by two phillips head screws. These screws should be removed before installation.

See Figure 3.

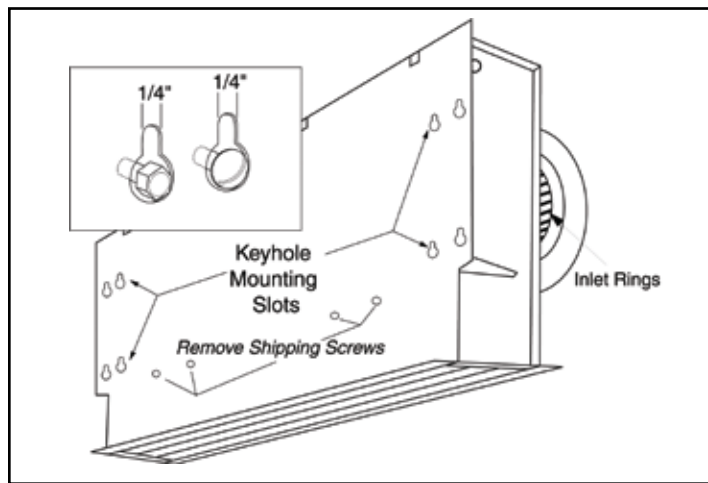

FIGURE 3 - Mounting Screws

- A. The Aristocrat/Star Series Air Door is equipped with 1/4" keyhole mounting slots on the back of each unit for wall mounting. It is recommended that a minimum of two keyhole slots are used from each end.

- B. Determine the exact mounting location of the Air Door unit.

NOTE: A minimum of 4" is recommended above the unit to provide clearance for installation and removal of the unit blower assembly.

- C. Choose four (4) keyhole slots that are located where suitable support is available for the unit. If the keyhole slots are not located where suitable support is available, drill new holes in the unit backplate where space is available.

- D. Mark the wall in the top center of the keyhole slots or in the center of the holes drilled.

E. **Keyhole Mounting:**

Install the mounting hardware (supplied by others), allowing for space to hang the unit by not fully tightening. Lift and slip the blower assembly over the mounting hardware by grasping the inlet rings on the blower housing, without touching the blower wheels. Tighten the mounting hardware. **See Figure 4.**

Drilled Mounting Holes:

Lift the blower assembly by grasping the inlet rings on the blower housing, without touching the blower wheels, and install the mounting hardware (supplied by others) through the drilled holes.

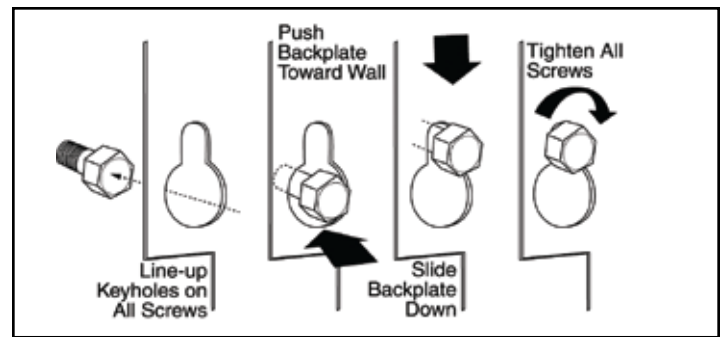

FIGURE 4 - Keyhole Mounting

- F. Do not install the cover housing at this time.

- G. Proceed to **Section V - ELECTRICAL CONNECTIONS.**

IV. SUSPENDED MOUNTING (Ceiling Suspension)

NOTE: TWO (2) TOP MOUNTING BRACKETS (PART#66LWA000TOP) ARE REQUIRED PER UNIT FOR SUSPENDED MOUNTING.

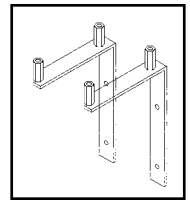

To prevent damage to the Air Door during shipping, the unit is shipped with each blower attached to the back plate by two phillips head screws. These screws should be removed before installation. **See Figure 3.**

- A. The Aristocrat/Star Series Air Door is equipped with keyhole mounting slots on the back of the unit. The top mounting brackets are designed to attach to these keyhole slots.
- B. Attach the top mounting brackets to the unit using the hardware provided.
- C. Determine the exact mounting location of the Air Door unit.
- D. Attach 3/8" threaded rods or other suitable hardware to the coupling nuts, located on the mounting bracket(s).
- E. Do not install the cover housing at this time.
- F. Proceed to **Section V - ELECTRICAL CONNECTIONS.**

V. ELECTRICAL CONNECTIONS

All electrical wiring and connections **MUST** be performed by qualified personnel in accordance with the latest edition of the National Electrical Code ANSI/NFPA No. 70 or, in Canada, the Canadian Electrical Code, Part 1-C.S.A. Standard C22.1 and local codes and regulations.

- A. Check the rating nameplate on the unit for supply voltage and current requirements. A separate line voltage supply with a suitable branch circuit protection device should be run directly from the main electrical panel to the unit. A disconnect switch for each branch circuit is a required part of this installation.

See Tables 2 & 3.

- B. All field wiring must be copper with a minimum insulation of 60° C within approved conduit. If any of the wire supplied with the unit must be replaced, it must be replaced with copper wiring with a minimum insulation of 90° C.
- C. Remove the junction box cover located on the right-hand side of the unit. **See Figure 5.**
- D. Connect all supply and control circuit wires according to the wiring diagram. To connect wiring from the left-hand side, an optional knockout is provided.

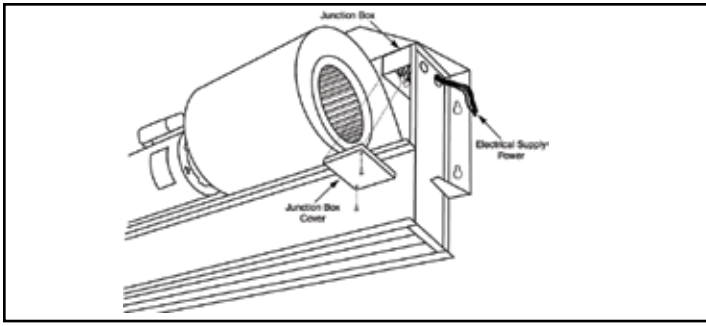

FIGURE 5 - Junction Box

NOTE: Electric heated units may be provided with a line voltage thermostat. Mount and wire thermostat according to instructions and the wiring diagram.

- E. Install the cover housing and attach it temporarily at each end of the unit with two of the cover screws provided. Final assembly should be done after airflow adjustments. **See Figure 6.**
- F. Switch on the power at the service disconnect. Turn on the unit and check the sequence of operation against the wiring diagram.
- G. Proceed to **Section VI - MECHANICAL CONNECTIONS** for electric heated units, otherwise proceed to **Section VII - AIRFLOW ADJUSTMENTS**

VI. MECHANICAL CONNECTIONS

A. ELECTRICALLY HEATED MODELS

The heater circuit may be controlled by a remote thermostat, or manually through a remote mounted three position - fan only/off/fan with heat switch. Overheating protection is provided by auto reset thermal cutouts built into the blower assembly (see wiring diagram). Proceed to **Section VII - AIRFLOW ADJUSTMENTS**.

MOTOR VOLTAGES/AMP DRAWS					
Horsepower	3/4	3/4	3/4	1/2	1/2
Speed	1	1	1	3	3
Volts	120	208/240	480	120	208/240
Phase	1	1	1	1	1
Hertz**	50/60	50/60	50/60	50/60	50/60
Amps per Motor	7.5	3.8	1.8	7.2	4.0

** Operation at 50 HZ will generate approximately a 17% reduction in performance.

TABLE 2 - Motor Amp Ratings

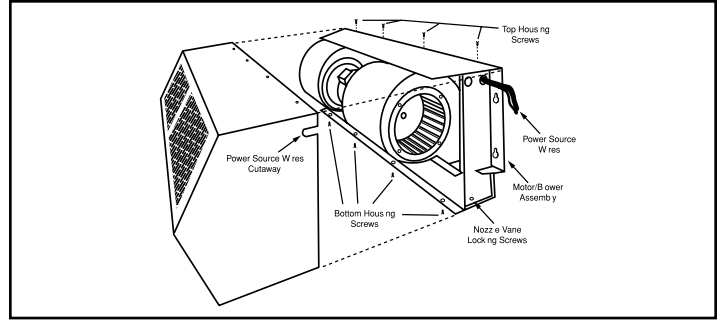

FIGURE 6 - Removing Cover

VII. AIRFLOW ADJUSTMENTS

- A. With the Air Door operating and the door in its full open position, check to see that nothing is obstructing the air flow at the discharge nozzle vanes.
- B. Find the air stream split location. Hold a handkerchief, by its corners, approximately 12" above the floor. Gently move the handkerchief back and forth in the doorway. Make sure the air is being directed to both the inside and the outside. The split location is indicated where the handkerchief is vertical with minimal or no fluttering. **See Figure 7.**
- C. Adjust the discharge nozzle vanes so the split location is approximately 3" outside the doorway. This is accomplished by first de-energizing the unit. Remove the cover housing, loosen the nozzle vane locking screws and adjusting vanes.
- D. Install remaining screws in cover housing.

ELECTRIC HEATER DATA									
Model	KW	208V 1Ø Amp Draw		240V 1Ø Amp Draw		240V 3Ø Amp Draw		240V 3Ø Amp Draw	480V 3Ø Amp Draw
		Circuit 1	Circuit 2	Circuit 1	Circuit 2	Circuit 1	Circuit 2	Circuit 1	Circuit 1
AS/ST*1036E	7.5	36.1	-	30.8	-	20.8	-	17.8	-
AS/ST*1042E	7.5	36.1	-	30.8	-	20.8	-	17.8	-
AS/ST*1048E	7.5	36.1	-	30.8	-	20.8	-	17.8	-
AS/ST*1060E-2	7.5	36.1	-	30.8	-	20.8	-	17.8	-
AS/ST*1036E	10	16.0	32.0	41.7	-	27.8	-	24.1	12.0
AS/ST*1042E	10	16.0	32.0	41.7	-	27.8	-	24.1	12.0
AS/ST*1048E	10	16.0	32.0	41.7	-	27.8	-	24.1	12.0
AS/ST*1060E-2	10	16.0	32.0	41.7	-	27.8	-	24.1	12.0
ASF/STF1060E-3	15	24.0	48.1	41.7	20.8	41.6	-	36.1	18.0
ASR/STR2060E	15	24.0	48.1	41.7	20.8	41.6	-	36.1	18.0
AS/ST*1072E	15	24.0	48.1	41.7	20.8	41.6	-	36.1	18.0
ASR/STR2072E	15	24.0	48.1	41.7	20.8	41.6	-	36.1	18.0
ASR/STR2072E	20.0	48.1	48.1	41.7	41.7	27.8	27.8	48.1	34.0

*Applies to both ASF/STF front door models and ASR/STR rear door models.

TABLE 3

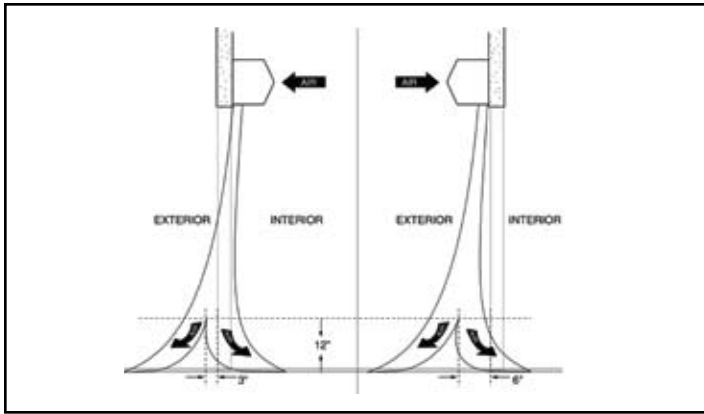

FIGURE 7 - Air Flow Adjustment

VIII. MAINTENANCE AND CLEANING

CAUTION: ELECTRIC SHOCK HAZARD

Disconnect power whenever servicing unit. More than one disconnect may be required to de-energize unit.

Keep your Air Door operating at peak efficiency by cleaning the blower wheels, motor(s) and intake grille. Buildup of dust on the blower wheels can cause vibration, noise and excessive wear on the motor bearings. The frequency of cleaning will depend on the environment where the unit is operating.

Dirty, dusty or greasy environments could require a cleaning schedule of once every two months. Otherwise, the unit(s) should be scheduled for cleaning a minimum of once every (6) months. To access the interior of the unit:

- A. Disconnect and lockout power to the unit. Remove unit cover housing by removing screws from the top and bottom of unit. Slide cover housing away from blower assembly to remove. If the unit has a filter, it should be removed and cleaned at this time. The filter is located in the cover housing and held in place by wing nuts and clips. **See Figure 8.**
- B. Vacuum and scrape (if necessary) to remove the buildup of dirt and debris from the interior of the Air Door. The motor(s) are permanently lubricated and require no additional lubrication. Reinstall the cover housing.
- C. Switch the power on after cleaning.

CAUTION: STAND CLEAR OF THE UNIT OR WEAR SAFETY GOGGLES AS LOOSE DEBRIS MAY BE PRESENT AND MAY EXIT THE NOZZLE.

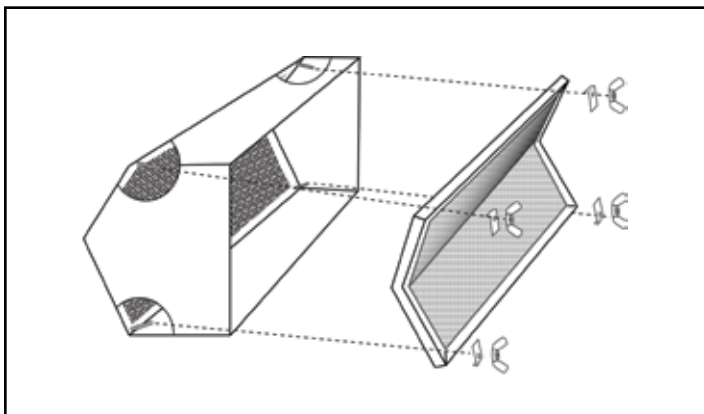

FIGURE 8 - Filter Replacement

IX. SERVICE

CAUTION: ELECTRIC SHOCK HAZARD Disconnect power whenever servicing unit. More than one disconnect may be required to de-energize unit.

*Any service performed on the Aristocrat/Star Series Air Door **MUST** be done by qualified personnel.*

Berner Air Doors require very little servicing. All parts are easily accessible for periodic inspection and maintenance. Units should be cleaned at least twice a year. Your particular application (the amount of dirt and dust in the air) and location of the unit(s) will determine how often your unit(s) will need to be cleaned and serviced. All motors have permanently lubricated, sealed, sleeve bearings and require no maintenance.

A. Fan Wheel Removal - Ambient and Electric Heated

1. Disconnect and lockout power to the unit. Remove unit cover housing by removing screws from the top and bottom of unit. Slide cover housing away from blower assembly to remove.
2. If unit is equipped with inlet rings and/or tri-arm bearings, remove outside ring and/or bearing using a blade screw driver or 1/4" nut driver. If unit does not have inlet rings proceed to next step.
3. Loosen (**do not remove**) 5/32" Allen head set screw from hub of fan wheel. Note: a T-handle Allen wrench may be inserted through hole in fan housing and fan blade with semi-circle notch.
4. Carefully slide fan wheel out of fan housing.
5. Reinstall fan wheel and align set screw with flat on motor shaft.
6. Slowly tighten set screw while gently rocking fan wheel back and forth to settle set screw perpendicular to motor shaft flat.
7. Reinstall inlet ring and/or bearing if necessary.
8. Reinstall unit cover housing and switch on power.

B. Motor Removal - Ambient and Electric Heated

1. Disconnect and lockout power to the unit. Remove unit cover housing by removing screws from the top and bottom of unit. Slide cover housing away from blower assembly to remove. For electric heated units, mark connections and disconnect four spade wire terminals from electric heater(s).
2. Unplug wiring harness from motor.
3. Loosen (**do not remove**) 5/32" Allen head set screw from hub of each fan wheel attached to motor. Note: a T-handle Allen wrench may be inserted through hole in fan housing and fan blade with semi-circle notch. If unit is equipped with an extended shaft and coupling for a three fan, one motor construction, this fan assembly must be disconnected from motor shaft. Loosen 5/32" set screw on third fan wheel hub. Loosen set screw on motor shaft side of coupling (silver coupling - 5/32" Allen wrench, black coupling - 9/64" Allen wrench). Slide coupling and shaft off motor shaft by gently pushing it through third fan hub.
4. Remove four phillips head screws from each fan housing that has a fan attached to motor.
5. Remove each fan and housing assembly from motor shaft by sliding away from motor. After fan wheel is off motor shaft, remove assembly by rotating it away from the blower assembly.

6. While supporting motor, loosen and remove two clips that hold motor with a straight blade screw driver or $\frac{5}{16}$ " nut driver.
7. Remove motor.
8. Install motor in reverse order of removal.

C. Fan Wheel and Housing Removal - Ambient and Electric Heated

1. Disconnect and lockout power to the unit. Remove unit cover housing by removing screws from the top and bottom of unit. Slide cover housing away from blower assembly to remove. For electric heated units, mark connections and disconnect four spade wire terminals from electric heaters.
2. Loosen (**do not remove**) $\frac{5}{32}$ " Allen head set screw from hub of fan wheel. Note: a T-handle Allen wrench may be inserted through hole in fan housing and fan blade with semi-circle notch.
3. Remove four phillips head screws from fan housing.
4. Remove fan and housing from motor shaft by sliding assembly away from motor. After fan wheel is off of motor shaft, remove assembly by rotating it away from blower assembly.
5. Reinstall in reverse order of removal.

D. Filter Replacement

1. Disconnect and lockout power to the unit. Remove unit cover housing by removing screws from the top and bottom of unit. Slide cover housing away from blower assembly to remove.
2. Filter is located in cover housing. Remove wing nuts and clips that hold filter. **See Figure 8.**
3. Remove and replace filter. Note: clean aluminum filters with water and a mild detergent, rinse thoroughly.
4. Reinstall in reverse order of removal.
Note: do not force or over tighten wing nuts as they will thread through the outside of cover housing.

E. Electric Heater Removal - Electric Heated

1. Disconnect and lockout power to the unit. Remove unit cover housing by removing screws from the top and bottom of unit. Slide cover housing away from blower assembly to remove. Mark connections and disconnect four spade wire terminals from electric heater(s).
2. Loosen (**do not remove**) $\frac{5}{32}$ " Allen head set screw from hub of fan wheel. Note: a T-handle Allen wrench may be inserted through hole in fan housing and fan blade with semi-circle notch.
3. Remove four phillips head screws from fan housing.
4. Remove fan and housing from motor shaft by sliding assembly away from motor. After fan wheel is off of motor shaft, remove assembly by rotating it away from blower assembly.
5. Remove electric heater element from fan housing by removing three screws with $\frac{1}{4}$ " nut driver.
6. Reinstall in reverse order of removal.

HOW A BERNER AIR DOOR WORKS

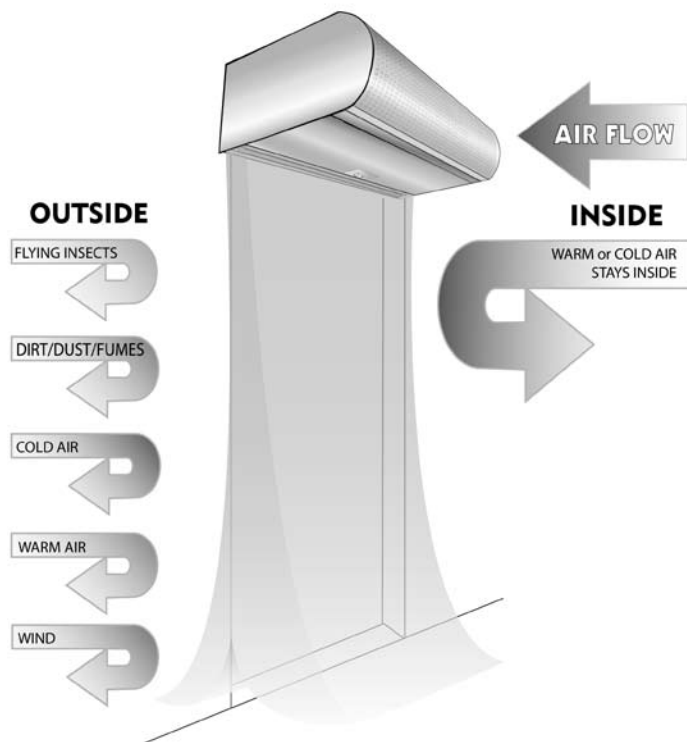

TROUBLESHOOTING

SYMPTOMS	CAUSE	REMEDY
NO AIR	<ul style="list-style-type: none"> • Electrical Power supply line open (no power) • Fuse blown/circuit breaker tripped • Motor overload tripped • Failed switch 	<ul style="list-style-type: none"> • Check power source, check method of control in ON position • Replace fuse(s)/reset breaker • Internally protected motor - should reset automatically after cool-down, if not replace motor. • Replace switch
	MOTOR RUNNING/FANS ARE NOT ROTATING	
	<ul style="list-style-type: none"> • Broken or fan hub • Shaft rotating inside fan • Broken/Loose coupling 	<ul style="list-style-type: none"> • Replace fan • Tighten set screws/tighten fan on shaft • Replace/Tighten coupling
	ELECTRICAL CONTROLS NOT FUNCTIONING WHEN DOOR IS OPEN	
	<ul style="list-style-type: none"> • Selector switch is in off position • Door limit switch not operating 	<ul style="list-style-type: none"> • Turn switch to "ON" position • Repair or replace limit switch
MINIMUM	<ul style="list-style-type: none"> • Air directional discharge vanes misadjusted • Inadequate intake clearance • Blower motor operates below speed • Fan rubbing against housing • Fan wheels clogged with dirt 	<ul style="list-style-type: none"> • Adjust vanes to proper position, see instructions • Move air curtain or remove obstruction Provide adequate space for air curtain • Improve voltage • Free fan from housing • Clean and vacuum fan wheels
AIR IS NOT HITTING FLOOR	<ul style="list-style-type: none"> • Air stream too weak • Air stream hits obstruction • Negative pressure 	<ul style="list-style-type: none"> • Adjust nozzle to proper position, adjust motor speed; see installation instructions • Remove obstruction or reposition air curtain (move out $\frac{3}{8}$" for every 1" up from the door) • Relieve negative pressure by providing make-up air
UNEVEN AIR	<ul style="list-style-type: none"> • Shaft rotating inside fan • One motor not operating 	<ul style="list-style-type: none"> • Tighten set screws/Replace fan • Repair or replace motor/Check electrical connections
EXCESSIVE AIR MOVEMENT AT DOORWAY	<ul style="list-style-type: none"> • Nozzle not angled out far enough • Air movement too cold • Pushing air outside building <p>SEE AIR IS NOT HITTING FLOOR SYMPTOMS</p>	<ul style="list-style-type: none"> • Adjust nozzle angle to outside • Add auxiliary heat to overcome wind chill • Adjust discharge angle back into building
ELECTRICALLY HEATED MODELS		
NO HEAT	<ul style="list-style-type: none"> • Switch turned to "OFF" position • Thermostat not set properly • Coils burned out due to lack of air • Automatic reset thermal cutout failed in open position • Manual reset thermal cutout tripped • Defective switch 	<ul style="list-style-type: none"> • Turn switch on • Change thermostat setting • Correct airflow problem; replace coils • Replace automatic thermal cutout • Reset manual thermal cutout • Replace switch
NOT ENOUGH HEAT	<ul style="list-style-type: none"> • Thermostat in wrong location - thermostat too close to discharge • Improper voltage • Thermostat not set properly 	<ul style="list-style-type: none"> • Move thermostat away from air stream • Supply proper voltage • Change temperature setting
TOO MUCH HEAT	<ul style="list-style-type: none"> • Thermostat in wrong location • Thermostat not set properly • Insufficient air over coil • Improper voltage 	<ul style="list-style-type: none"> • Move thermostat closer to air stream • Change temperature setting • Remove restriction on intake • Supply proper voltage

WARRANTY

Berner International warrants all new equipment to be free of defects in workmanship and material for a period of five years (5 years) on unheated models and two years (2 years) on heated models from the original date of shipment, provided the equipment has been properly cared for, installed and operated in accordance with the limits specified on the nameplate and The Company's instructions.

The Company will correct by repair or replacement, at its option and expense, any proven defects in said apparatus, subject to the above conditions, provided that immediate written notice of such defects is given to The Company. The warranty does not include any labor incurred for the removal or installation of defective part(s). The Company reserves the right to inspect, or have inspected by a qualified representative, any apparatus at the place of installation before authorizing repair or replacement. Repair or replacement will be made F.O.B. factory with any applicable transportation charges to be borne by the customer. Merchandise not of The Company's manufacture supplied in piece, or in component assemblies, is not covered by the above warranty, but The Company will give the customer the benefit of any adjustment as made with the Manufacturer.

This warranty is void if the apparatus has been tampered with in any way or shows evidence of misuse.

The Company will not assume any expense or liability for repairs made outside its factory without proper written consent from its service manager, nor for any transportation charges on apparatus returned to the factory without written authorization by The Company.

Nothing in the above warranty provisions, however, shall impose any liability or obligation of any type, nature or description upon Berner International if Berner has not received payment in full for the apparatus in question.

THERE ARE NO WARRANTIES WHICH EXTEND BEYOND THE DESCRIPTION ON THE FACE HERE OF INCLUDING THE IMPLIED WARRANTY OF MERCHANTABILITY AND FITNESS FOR A PARTICULAR PURPOSE.

LIMITATION OF DAMAGES

Notwithstanding anything to the contrary above, customer's exclusive remedy for any and all losses or damages resulting from the sale of The Company's equipment under this agreement, including but not limited to, any allegations of breach of warranty, breach of contract, negligence or strict liability, shall be limited, at The Company's option, to either the return of the purchase price or the replacement of the particular equipment for which a claim is made and proved. In no event shall The Company be liable for any special, consequential, incidental or indirect losses or damages from the sale of The Company's equipment under this agreement.

SERIAL NUMBER	MODEL NUMBER	DATE PURCHASED
---------------	--------------	----------------



BERNER INTERNATIONAL CORPORATION
New Castle, Pennsylvania

724-658-3551 • 1-800-245-4455 • www.berner.com • airdoors@berner.com

Berner reserves the right to alter specifications without prior notice.