

CFC TOP INTAKE AMBIENT SYSTEM

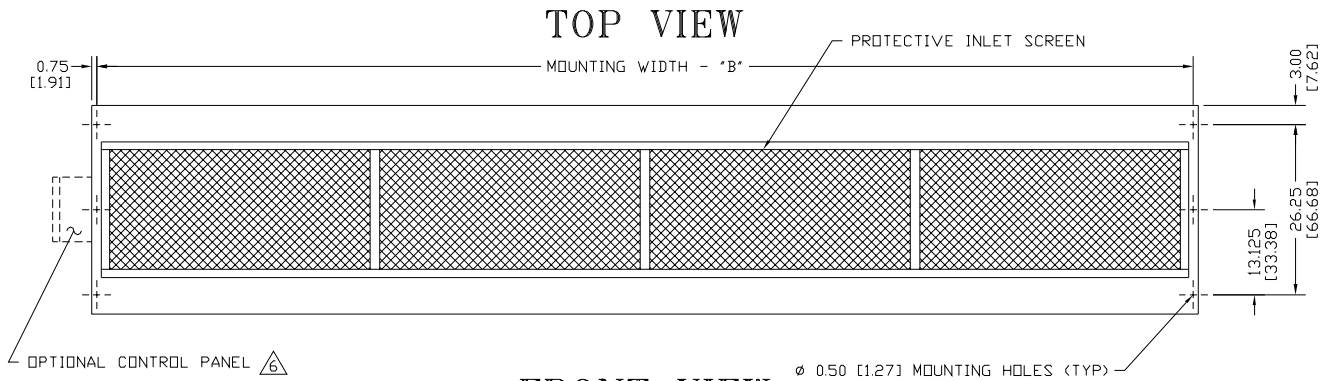

END VIEW

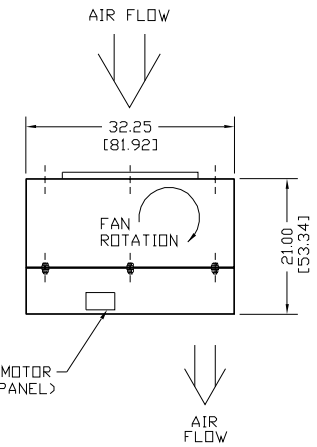

ONE JUNCTION BOX PER MOTOR
(REQUIRED FOR REMOTE PANEL)
2.75 x 4.50 x 2.00
[6.99 x 11.43 x 5.08]

FRONT VIEW

BOTTOM VIEW

NOTES:

- ⚠ AIR CURTAIN MUST BE INSTALLED SO AIR STREAM IS NOT OBSTRUCTED WHEN DEFLECTED 20° TO EITHER SIDE OF ϕ .
- ⚠ ELECTRICAL CONNECTIONS TO BE FLEXIBLE.
- ⚠ FIELD VERIFY DIMENSIONS.
- ⚠ ANCHORS TO SUPPORTING STRUCTURE BY OTHERS.
- ⚠ ADEQUACY OF SUPPORTING STRUCTURE IS TO BE VERIFIED BY A PROFESSIONAL STRUCTURAL ENGINEER.
- ⚠ OPTIONAL CONTROL PANEL AVAILABLE: LEFT HAND MOUNT, RIGHT HAND MOUNT, OR REMOTE. PLEASE SPECIFY.
- ⚠ DIMENSIONS IN INCHES (CENTIMETERS).

OPTIONAL CONTROL PANEL ⚠

DAMPER CONTROL (TYP) ⚠

NOZZLE ANGLE ADJUSTMENT (TYP) ⚠

MODEL	NOZZLE WIDTH "A"	MOUNTING WIDTH "B"	UNIT WIDTH "C"
CFC1060A-T	60.00 [152.40]	61.50 [156.21]	63.00 [160.02]
CFC1072A-T	72.00 [182.88]	73.50 [186.69]	75.00 [190.50]
CFC1084A-T	84.00 [213.36]	85.50 [217.17]	87.00 [220.98]
CFC1096A-T	96.00 [243.84]	97.50 [247.65]	99.00 [251.46]
CFC1108A-T	108.00 [274.32]	109.50 [278.13]	111.00 [281.94]
CFC1120A-T	117.00 [297.18]	118.50 [300.99]	120.00 [304.80]
CFC1132A-T	132.00 [335.28]	133.50 [339.09]	135.00 [342.90]
CFC1144A-T	144.00 [365.76]	145.50 [369.57]	147.00 [373.38]
CFC1156A-T	156.00 [396.24]	157.50 [400.05]	159.00 [403.86]
CFC1168A-T	168.00 [426.72]	169.50 [430.53]	171.00 [434.34]
CFC1180A-T	180.00 [457.20]	181.50 [461.01]	183.00 [464.82]
CFC2192A-T	192.00 [487.68]	193.50 [491.49]	195.00 [495.30]

PROJECT		
LOCATION		
ARCHITECT		
ENGINEER		REV. A
DWG. NO.	CFCQ3182	TITLE: BERNER MODEL CFC AIR CURTAIN TOP INTAKE AMBIENT SYSTEM
DATE	29JUN06	
BY	A. Johnston	
REPLACES	25NOV02	
BY	B. Peffer	BERNER INTERNATIONAL CORP. NEW CASTLE, PA