

TOP VIEW

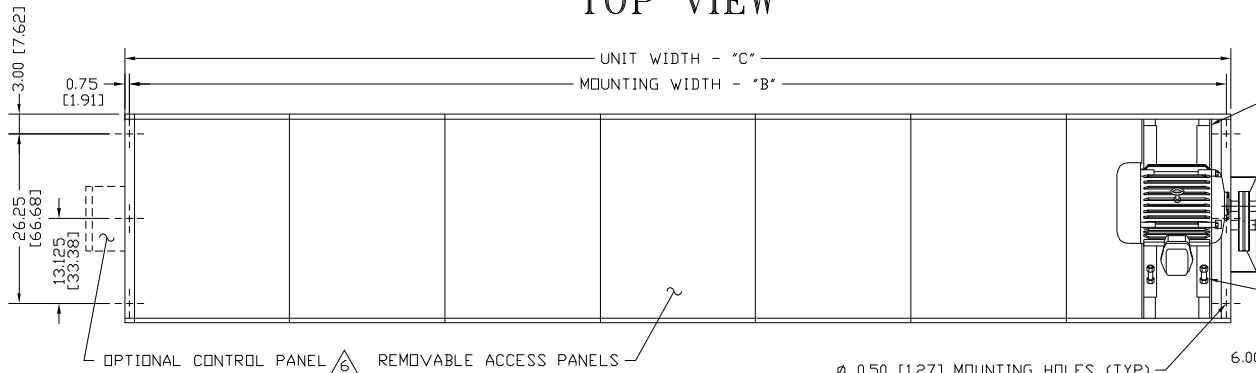

CFX FRONT INTAKE AMBIENT SYSTEM

END VIEW

(BELT GUARD REMOVED)

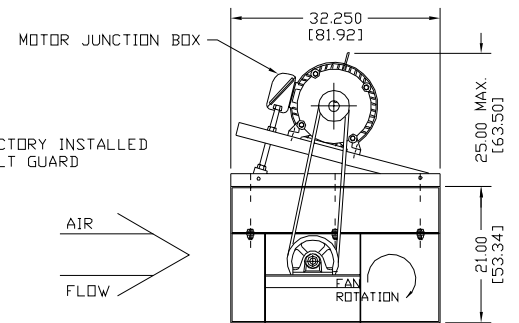

FRONT VIEW

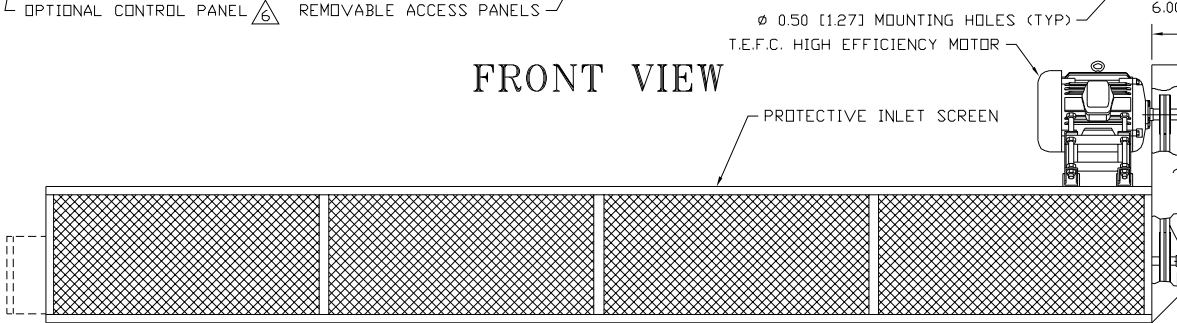

BOTTOM VIEW

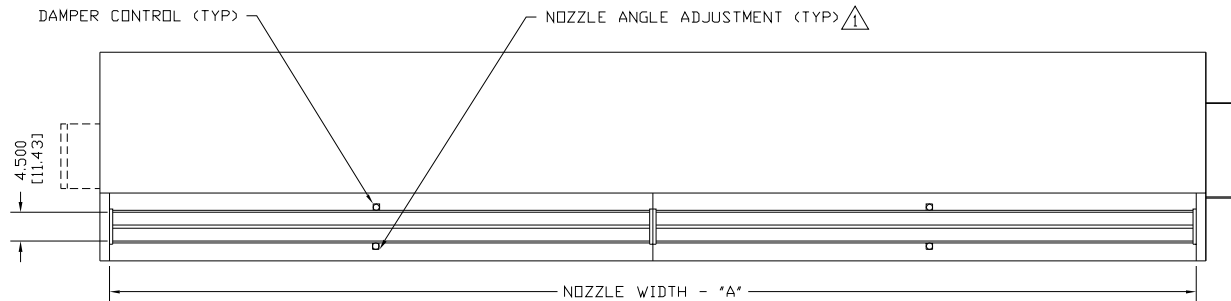

NOTES:

- ⚠️ AIR CURTAIN MUST BE INSTALLED SO AIR STREAM IS NOT OBSTRUCTED WHEN DEFLECTED 20° TO EITHER SIDE OF C.
- ⚠️ ELECTRICAL CONNECTIONS TO BE FLEXIBLE.
- ⚠️ FIELD VERIFY DIMENSIONS.
- ⚠️ ANCHORS TO SUPPORTING STRUCTURE BY OTHERS.
- ⚠️ ADEQUACY OF SUPPORTING STRUCTURE IS TO BE VERIFIED BY A PROFESSIONAL STRUCTURAL ENGINEER.
- ⚠️ OPTIONAL CONTROL PANEL AVAILABLE: LEFT HAND MOUNT, RIGHT HAND MOUNT, OR REMOTE. PLEASE SPECIFY.
- ⚠️ DIMENSIONS IN INCHES (CENTIMETERS).

MODEL	NOZZLE WIDTH "A"	MOUNTING WIDTH "B"	UNIT WIDTH "C"
CFX1060A-F	60.00 [152.40]	61.50 [156.21]	63.00 [160.02]
CFX1072A-F	72.00 [182.88]	73.50 [186.69]	75.00 [190.50]
CFX1084A-F	84.00 [213.36]	85.50 [217.17]	87.00 [220.98]
CFX1096A-F	96.00 [243.84]	97.50 [247.65]	99.00 [251.46]
CFX1108A-F	108.00 [274.32]	109.50 [278.13]	111.00 [281.94]
CFX1120A-F	117.00 [297.18]	118.50 [300.99]	120.00 [304.80]
CFX1132A-F	132.00 [335.28]	133.50 [339.09]	135.00 [342.90]
CFX1144A-F	144.00 [365.76]	145.50 [369.57]	147.00 [373.38]
CFX1156A-F	156.00 [396.24]	157.50 [400.05]	159.00 [403.86]
CFX1168A-F	168.00 [426.72]	169.50 [430.53]	171.00 [434.34]
CFX1180A-F	180.00 [457.20]	181.50 [461.01]	183.00 [464.82]
CFX1192A-F	192.00 [487.68]	193.50 [491.49]	195.00 [495.30]

PROJECT		
LOCATION		
ARCHITECT		
ENGINEER		REV. A
DWG. NO.	CFAR3204	TITLE: BERNER
DATE	29JUN06	MODEL CFX AIR CURTAIN
BY	A. Johnston	FRONT INTAKE BELT DRIVE AMBIENT SYSTEM
REPLACES	04APR03	
BY	B. Peffer	BERNER INTERNATIONAL CORP. NEW CASTLE, PA.