

# CFY

- DIRECT GAS FIRED HEATER SYSTEM
- BELT DRIVE
- FRONT INTAKE

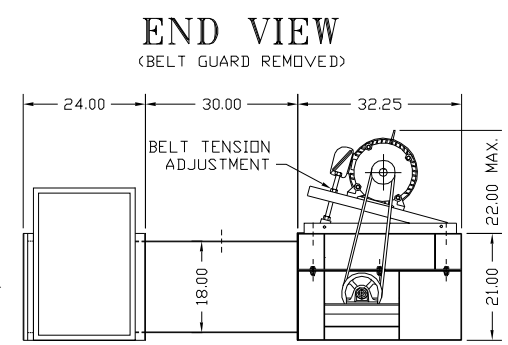
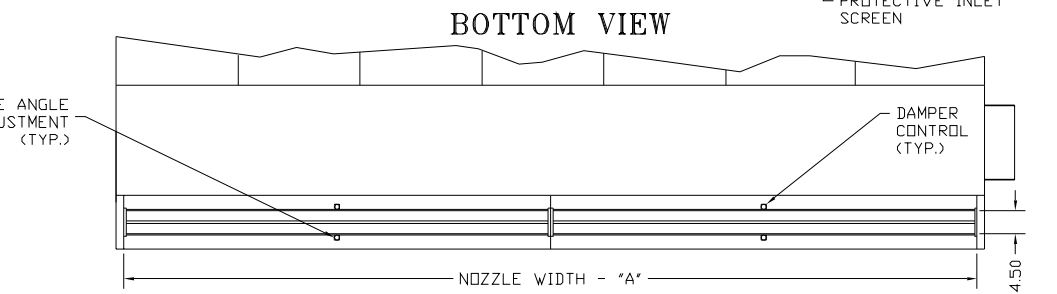
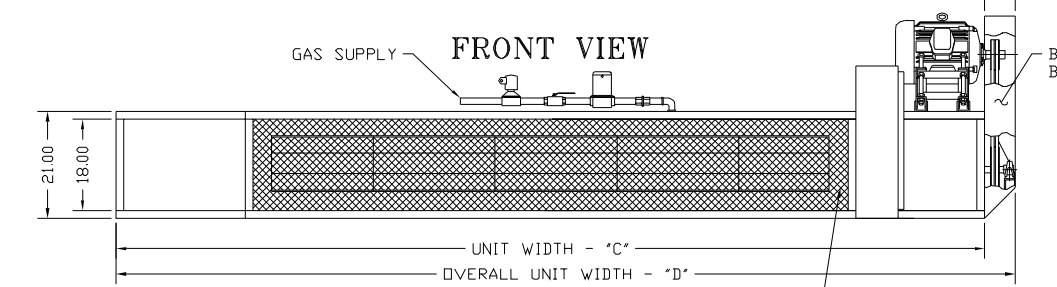

- NOTES:**
- 1 AIR CURTAIN MUST BE INSTALLED SO AIR STREAM IS NOT OBSTRUCTED WHEN DEFLECTED 20° TO EITHER SIDE OF  $\phi$ .
  - 2 ELECTRICAL CONNECTIONS TO BE FLEXIBLE.
  - 3 FIELD VERIFY DIMENSIONS.
  - 4 ANCHORS TO SUPPORTING STRUCTURE BY OTHERS.
  - 5 ADEQUACY OF SUPPORTING STRUCTURE IS TO BE VERIFIED BY A PROFESSIONAL STRUCTURAL ENGINEER.
  - 6 SUPPORT DIRECT GAS HEATER SEPARATELY FROM UNIT.

SHEET 1 OF 2

PROJECT		
LOCATION		
ARCHITECT		
ENGINEER		REV. A
DWG. NO.	DGFR0127	TITLE: <b>BERNER</b> CFY DIRECT GAS FIRED FRONT INTAKE; BELT DRIVE
DATE	29JUN06	
BY	A. Johnston	
REPLACES	07SEPT04	
BY	A. JOHNSTON	BERNER INTERNATIONAL CORP. NEW CASTLE, PA.

# CFY

- DIRECT GAS FIRED
- HEATER SYSTEM
- BELT DRIVE
- FRONT INTAKE

MODEL	NOZZLE WIDTH "A"	MOUNTING WIDTH "B"	UNIT WIDTH "C"	OVERALL WIDTH "D"	BURNER WIDTH "E"	MOUNTING WIDTH "F"	INTAKE WIDTH "G"
CFY1060D-F	60.00	61.50	63.00	69.00	39.00	37.50	36.00
CFY1072D-F	72.00	73.50	75.00	81.00	51.00	49.50	48.00
CFY1084D-F	84.00	85.50	87.00	93.00	51.00	49.50	48.00
CFY1096D-F	96.00	97.50	99.00	105.00	63.00	61.50	60.00
CFY1108D-F	108.00	109.50	111.00	117.00	75.00	73.50	72.00
CFY1120D-F	117.00	118.50	120.00	126.00	87.00	85.50	84.00
CFY1132D-F	132.00	133.50	135.00	141.00	99.00	97.50	96.00
CFY1144D-F	144.00	145.50	147.00	153.00	111.00	109.50	108.00
CFY1156D-F	156.00	157.50	159.00	165.00	120.00	118.50	117.00
CFY1168D-F	168.00	169.50	171.00	177.00	120.00	118.50	117.00
CFY1180D-F	180.00	181.50	183.00	189.00	120.00	118.50	117.00
CFY1192D-F	192.00	193.50	195.00	201.00	120.00	118.50	117.00

## NOTES:

- ① AIR CURTAIN MUST BE INSTALLED SO AIR STREAM IS NOT OBSTRUCTED WHEN DEFLECTED 20° TO EITHER SIDE OF U.
- ② ELECTRICAL CONNECTIONS TO BE FLEXIBLE.
- ③ FIELD VERIFY DIMENSIONS.
- ④ ANCHORS TO SUPPORTING STRUCTURE BY OTHERS.
- ⑤ ADEQUACY OF SUPPORTING STRUCTURE IS TO BE VERIFIED BY A PROFESSIONAL STRUCTURAL ENGINEER.
- ⑥ SUPPORT DIRECT GAS HEATER SEPARATELY FROM UNIT.

SHEET 2 OF 2

PROJECT			
LOCATION			
ARCHITECT			
ENGINEER			REV. A
DWG. NO.	DGFR0127	TITLE:	<b>BERNER</b>
DATE	29JUN06		CFY DIRECT GAS FIRED
BY	A.Johnston		FRONT INTAKE; BELT DRIVE
REPLACES	07SEPT04	BERNER INTERNATIONAL CORP.	
BY	A.JOHNSTON	NEW CASTLE, PA.	