

CFY FRONT INTAKE STEAM/HOT WATER SAME END SUP./RET.

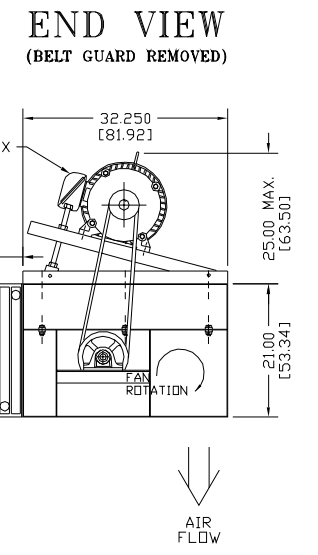
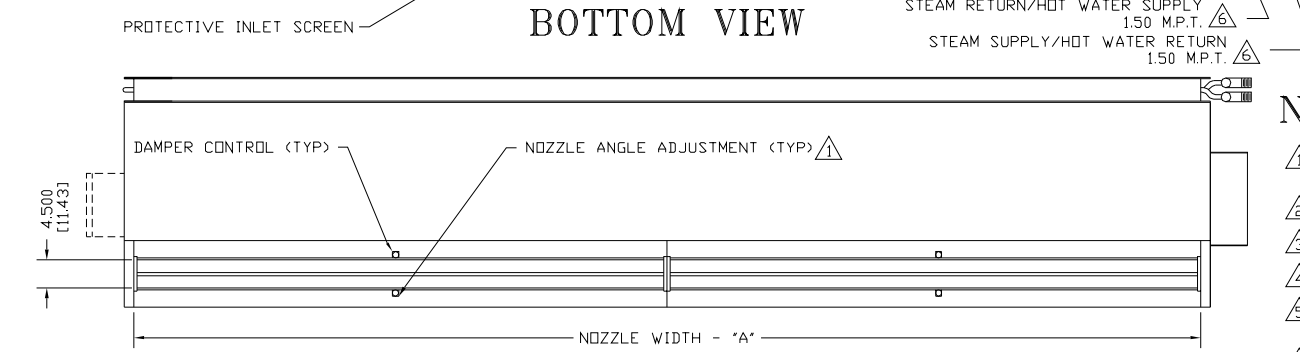
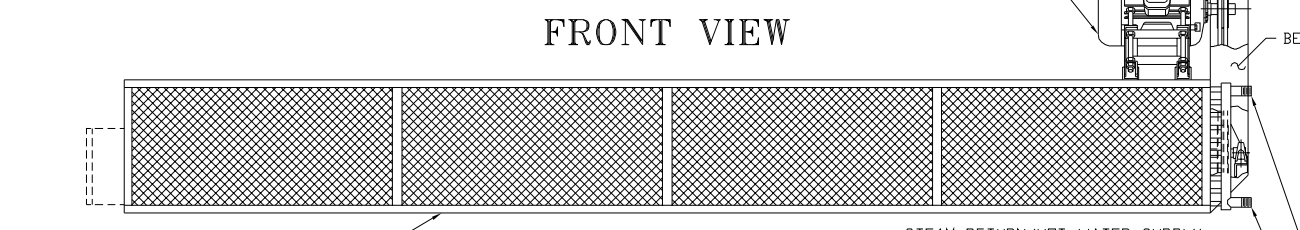
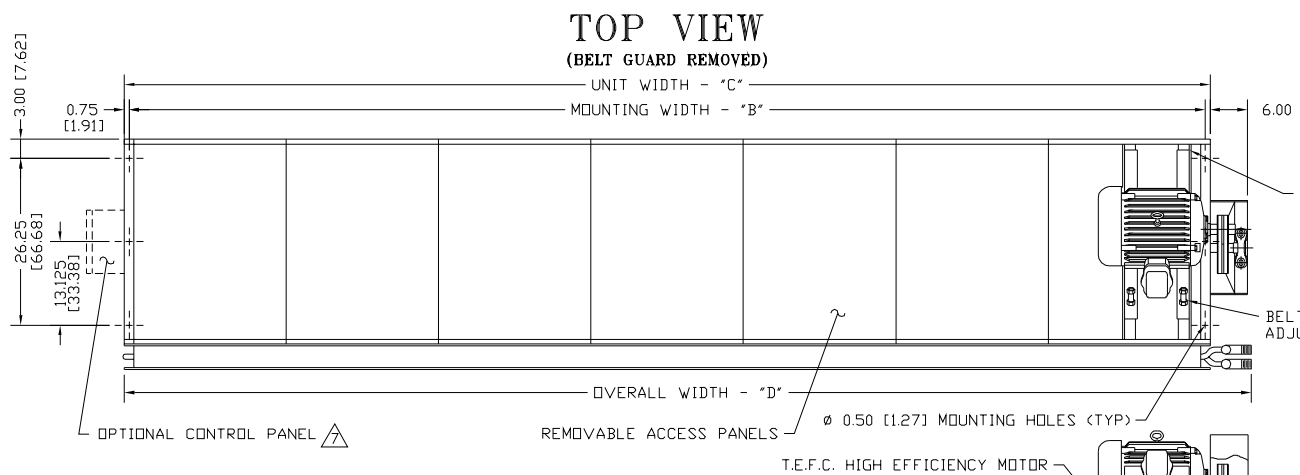

NOTES:

- 1. AIR CURTAIN MUST BE INSTALLED SO AIR STREAM IS NOT OBSTRUCTED WHEN DEFLECTED 20° TO EITHER SIDE OF C.
- 2. ELECTRICAL CONNECTIONS TO BE FLEXIBLE.
- 3. FIELD VERIFY DIMENSIONS.
- 4. ANCHORS TO SUPPORTING STRUCTURE BY OTHERS.
- 5. ADEQUACY OF SUPPORTING STRUCTURE IS TO BE VERIFIED BY A PROFESSIONAL STRUCTURAL ENGINEER.
- 6. COIL CONNECTIONS AS SHOWN, OPPOSITE AND SAME END CONNECTIONS AVAILABLE, PLEASE SPECIFY.
- 7. OPTIONAL CONTROL PANEL AVAILABLE: LEFT HAND MOUNT, RIGHT HAND MOUNT, OR REMOTE. PLEASE SPECIFY.
- 8. DIMENSIONS IN INCHES (CENTIMETERS).

MODEL	NOZZLE WIDTH "A"	MOUNTING WIDTH "B"	UNIT WIDTH "C"	OVERALL WIDTH "D"
CFY1060*-F	60.00 [152.40]	61.50 [156.21]	63.00 [160.02]	69.50 [176.53]
CFY1072*-F	72.00 [182.88]	73.50 [186.69]	75.00 [190.50]	81.50 [207.01]
CFY1084*-F	84.00 [213.36]	85.50 [217.17]	87.00 [220.98]	93.50 [237.49]
CFY1096*-F	96.00 [243.84]	97.50 [247.65]	99.00 [251.46]	105.50 [267.97]
CFY1108*-F	108.00 [274.32]	109.50 [278.13]	111.00 [281.94]	117.50 [298.45]
CFY1120*-F	117.00 [297.18]	118.50 [300.99]	120.00 [304.80]	126.50 [321.31]
CFY1132*-F	132.00 [335.28]	133.50 [339.09]	135.00 [342.90]	141.50 [359.41]
CFY1144*-F	144.00 [365.76]	145.50 [369.57]	147.00 [373.38]	153.50 [389.89]
CFY1156*-F	156.00 [396.24]	157.50 [400.05]	159.00 [403.86]	165.50 [420.37]
CFY1168*-F	168.00 [426.72]	169.50 [430.53]	171.00 [434.34]	177.50 [450.85]
CFY1180*-F	180.00 [457.20]	181.50 [461.01]	183.00 [464.82]	189.50 [481.33]
CFY1192*-F	192.00 [487.68]	193.50 [491.49]	195.00 [495.30]	210.50 [511.81]

* S - STEAM; W - WATER

PROJECT		
LOCATION		
ARCHITECT		
ENGINEER		REV. A
DWG. NO.	CFCR3212	TITLE: BERNER
DATE	29JUN06	MODEL CFY AIR CURTAIN
BY	A. Johnston	FRONT INTAKE BELT DRIVE STEAM/HOT WATER
REPLACES	05MAY03	
BY	B. Peffer	BERNER INTERNATIONAL CORP. NEW CASTLE, PA.