

PORTABLE

MODEL	BTU (hr)	Gas	Ignition	Finish	Dimension H x W	Wheels	Cylinder/Counter Weight	Weight (lbs)
PHB1001LP	38,000	LP	BATTERY SPARK	STAINLESS STEEL	89 3/4" x 32 1/4"	YES	30 or 20 lb. Cyl.	37
PHB1003LP	38,000	LP	BATTERY SPARK	BLACK	89 3/4" x 32 1/4"	YES	30 or 20 lb. Cyl.	37

FIXED POST MOUNT

MODEL	BTU (hr)	Gas	Ignition	Finish	Dimension H x W	GAS PRESSURE		Gas Inlet	Mounting	Weight (lbs)
						Manifold	Max. Inlet			
PHB1004NG	38,000	NATURAL	BATTERY SPARK	BLACK	88 1/5" x 32"	5" W.C.	14" W.C.	1/2"	Floor/Deck	50
PHB1004LP	38,000	LP	BATTERY SPARK	BLACK	88 1/5" x 32"	10" W.C.	14" W.C.	1/2"	Floor/Deck	50
PHB1004NG-SS	38,000	NATURAL	BATTERY SPARK	STAINLESS STEEL	88 1/5" x 32"	5" W.C.	14" W.C.	1/2"	Floor/Deck	50
PHB1004LP-SS	38,000	LP	BATTERY SPARK	STAINLESS STEEL	88 1/5" x 32"	10" W.C.	14" W.C.	1/2"	Floor/Deck	50

All models have 32" diameter one piece reflector

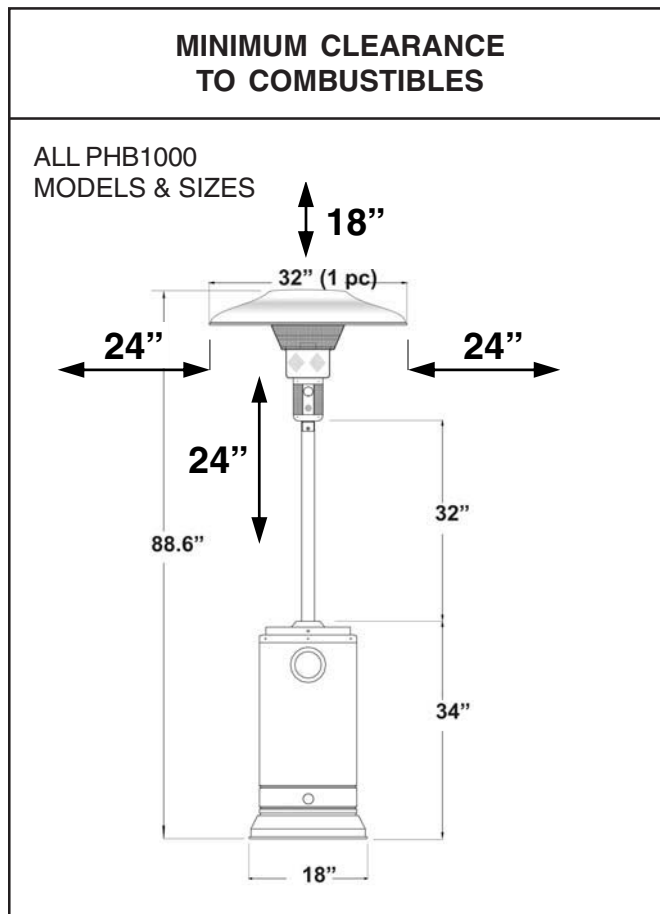

PORTABLE MODELS PHB1001/1003 SHIPPING: DISPLAY CARTON = 18" X 18" X 35" + REFLECTOR CARTON
FIXED MODELS PHB1004 SHIPS IN THREE CARTONS: BURNER & BASE, POST, REFLECTOR

